



One City Plaza, Suite B
P.O. Box 1287
Cabot, Arkansas 72023
Phone 501-843-4654

**Cabot WaterWorks
Standard Construction Specifications
Water & Wastewater Facilities**

Revised: March 10, 2023

Contents

1. GENERAL REQUIREMENTS - WATER & WASTEWATER 3

2. MATERIALS APPROVED FOR CONSTRUCTION 10

3. PROTECTION OF VEGETATION..... 13

4. LOCATION, ALIGNMENT AND GRADE 14

5. PIPE TRENCH CONSTRUCTION WATER & WASTEWATER..... 15

6. PIPE BEDDING & BACKFILL WATER & WASTEWATER 16

7. PIPE INSTALLATION – GENERAL WATER & WASTEWATER 18

8. JOINTING PUSH-ON (BELL) JOINT PIPE & FITTINGS..... 19

9. MECHANICAL JOINT & RESTRAINED JOINT PIPE & FITTINGS 21

10. JOINTING FLANGED PIPE & FITTINGS 22

11. JOINTING POLYETHYLENE (PE) PIPE 22

12. JOINTING ASBESTOS-CEMENT PIPE 22

13. VALVE INSTALLATION 22

14. TAPPING SLEEVE & TAPPING SADDLES..... 24

15. AIR/VACUUM RELIEF VALVES 24

16. STEEL PIPE FOR CREEK CROSSINGS 25

17. FIRE HYDRANT INSTALLATION..... 25

18. DEAD-END WATER MAINS W/ BLOW-OFFS..... 28

19. POLYETHYLENE ENCASEMENT FOR DUCTILE IRON PIPE..... 28

20. ENCASEMENT STRUCTURES (OPEN CUT OR DIRECTIONAL BORING) 30

21. CONCRETE THRUST BLOCKS & ANCHOR COLLARS FOR PIPE FITTINGS..... 32

22. CONCRETE MIX - PLACEMENT & FINISHING CONCRETE 34

23. REPLACEMENT OF PAVED SURFACES..... 40

24. TEMPORARY REPAIRS TO PAVED SURFACES 41

25. CONNECTIONS TO CWW DISTRIBUTION AND COLLECTION SYSTEM 41

26. FILLING WATER PIPELINES 41

27. CLEANING LARGE WATER PIPELINES 41

28. HYDROSTATIC PRESSURE AND LEAKAGE TESTS WATER & SEWER FORCE MAINS..... 42

29. FLUSHING WATER PIPELINES 43

30. DISINFECTING WATER PIPELINES & APPURTENANCES 44

31. WATER METERS, SERVICE LINES AND CONNECTIONS 46

32. SANITARY SEWER MANHOLES 50

33. SANITARY SEWER GRAVITY PIPELINES..... 53

34. WASTEWATER SERVICE CONNECTIONS 55

35. CONNECTIONS TO EXISTING SEWER SERVICE LINES 58

36. GREASE TRAPS AND GREASE INTERCEPTORS 59

37. OIL SEPARATORS AND GRIT INTERCEPTORS..... 60

38. WASTEWATER PUMP STATIONS..... 61

39. WASTEWATER FORCE MAINS 69

40. LOW PRESSURE GRINDER PUMP SYSTEMS..... 69

41. RESTORATION AND CLEAN-UP OF JOB SITE 72

42. GUARANTEE 72

43. RECORD DRAWINGS & FINAL CONSTRUCTION COSTS 72

Cabot WaterWorks Standard Construction Specifications

Definitions of terms: Whenever used in these specifications or the contract document the following terms shall have meanings as follows:

- (a) ADEQ: Arkansas Department of Environmental Quality
- (b) ARDOT: Arkansas Department of Transportation
- (c) CWW: **Cabot WaterWorks**
- (d) OWNER: **Cabot WaterWorks**
- (e) Developer: A person, firm or corporation who constructs any type of building and/or who sales land which has been subdivided for sale, lease or rent.
- (f) Engineer: CWW' authorized Engineer, either acting directly or through field engineers or inspectors, such field engineers or inspectors acting within the scope of the particular duties assigned to them.
- (g) CONTRACTOR: Firm, Corporation or Developer executing the contract with CWW for the performance of the work hereunder.
- (h) Superintendent or Foreman: Representative of CONTRACTOR, authorized to receive and fulfill instructions from Engineer.
- (i) Contract: The contract consists of the instructions to bidders, the proposal, the contract agreement, the specifications, plans, supplemental specifications and other supplemental agreements all as required for the full execution and satisfactory completion of the work.
- (j) Plans: The approved maps, standard drawings, supplemental drawings and sketches which show the location, character, dimensions and details of the work to be done. CONTRACTOR will be supplied with copies of the plans and specifications. Any alterations affecting the requirements and information given in the plans and specifications shall be authorized in writing.
- (k) Specifications: The directions, provisions and requirements contained herein and referred to pertaining to the work.
- (l) Supplemental Specifications: Specific instructions setting forth conditions or requirements peculiar to the project under consideration not completely covered by the specifications.
- (m) Supplemental Agreements: The written agreements executed by CONTRACTOR and CWW covering alterations in the contract, unforeseen work and materials incident and necessary to the project.
- (n) The Work: All work specified herein and as indicated on the various plans as may be furnished to CONTRACTOR from time to time.
- (o) Title: The title to all work completed and in the course of construction at the site and of all materials furnished by CWW, irrespective of the location thereof as between CWW and CONTRACTOR or subcontractors, shall be CWW.
- (p) Authority of Engineer: The Engineer shall decide any and all questions which may arise as to the quality and acceptability of work performed and the rate of progress of the work and shall decide all questions that may arise as to the interpretation of the plans and specifications and all questions as to the acceptable fulfillment of the terms of the contract.
- (q) Assistants: The Engineer may appoint such assistants as he desires. They shall have the authority to give instructions pertaining to the work, to approve or reject work, to make measurements of quantities, to keep records of cost, and otherwise represent the Engineer. The assistants shall not be authorized to revoke, alter, enlarge, relax or release any requirement of the contract agreement, plans and specifications nor shall they act as foreman for the CONTRACTOR.
- (r) Undeveloped Areas: New subdivisions and private or public rights-of-way where other utilities facilities are not present and where traffic maintenance is not major concern.
- (s) Developed Areas: Old subdivisions and other developed areas along private or public rights-of-way where other utilities' facilities are present and do cross the path of CWW' proposed pipeline route and where traffic maintenance is of major concern.
- (t) Test Hole: Excavation made at Engineer's request prior to start of project for the purpose of determining location of existing facilities to aid in choice of alignment and grade for pipelines. To include excavation and tamped backfilling of hole approximately 4 feet wide x 4 feet long x 6 feet deep and reseeding or sodding surface. Removal and replacement of paving not to be included.

1. GENERAL REQUIREMENTS - WATER & WASTEWATER

1.1 ARKANSAS DEPARTMENT of HEALTH APPROVAL

- a). The Arkansas Department of Health (ADH) shall approve all construction plans and specifications for the construction of new systems or extensions, expansions or modifications of existing systems.
- b). The Arkansas Department of Health (ADH) shall approve plans for Cross-Connection Control on Fire Protection Systems prior to installation.
- c). Cabot Waterworks requires all Water and Wastewater facilities to conform to the most current addition of the **“RECOMMENDED STANDARDS FOR WATERWORKS (AND WASTEWATER) FACILITIES”** published by Great Lakes - Upper Mississippi River Board of State and Provincial Public Health and Environmental Managers, (10 States Standards).

Cabot WaterWorks Standard Construction Specifications

1.2 COPIES OF DRAWINGS AND SPECIFICATIONS

- a). Developers will furnish Cabot Waterworks full-size Drawings and Specifications (hard copies and electronic files) at no cost to the Cabot Waterworks.
- b). For Cabot Waterworks funded projects: The Owner will furnish the Contractor one set of full-size Drawings and Specifications at no cost to the Contractor. Additional sets may be obtained from the Owner at the cost of reproduction and delivery.
- c). To Subcontractors: Additional sets may be obtained by the Contractor (or Subcontractor) from the Engineer at the cost of reproduction and delivery.

1.3 PROJECT WORKING HOURS

- a). **Normal project working hours for this project are Monday through Friday between the hours of 8:00 am and 4:30pm. Work shall not be performed on Saturdays, Sundays or legal holidays, except by written permission of an official of CWW.**
- b). **The Contractor shall notify Cabot WaterWorks representative 24hours prior to excavation work in order to schedule inspection of all underground facilities and pipe installed. Pipe bedding shall be inspected by CWW' representative prior to backfilling.**
- c). The Contractor shall compensate Cabot Waterworks for the actual salary costs (base salary plus overtime pay) and expenses incurred as a result of the Contractor choosing to work outside the normal project working hours.
- d). The Contractor may perform clean-up work outside of regular hours with the approval of the Engineer. Clean-up work shall be approved by the Engineer at least 24 hours prior to work taking place.

1.4 DESCRIPTION AND SCOPE OF WORK

- a). The work included in the Contract consists of the furnishing of all tools, labor, equipment, materials, and supplies necessary to fully construct the project with all incidental and ancillary work as shown on the Drawings. Installation is to be complete and inclusive of pipe, fittings, bedding material, backfill material, concrete, final connections to existing utility line(s), traffic control, trench safety, and restoration of streets and property. All water and wastewater facility testing requirements outlined in these specifications shall be the responsibility of the Contractor.
- b). Work or material not specifically mentioned in the Specifications, but designated on the Drawings, or forming an essential part of the Work mentioned or designated, shall be furnished and installed by the Contractor as though specifically mentioned.
- c). Construction of the work shall be by one General Contractor, utilizing Subcontractors for those specialties and portions of the Work that the General Contractor chooses to subcontract. All Subcontractors are subject to approval by the Owner in accordance with Contract and applicable sections of the Specifications. The General Contractor shall maintain a responsible representative on-site whenever his subcontractors are on-site and engaged in the Work.
- d). The Drawings show the proposed location and details of construction work in this Contract. All work shall be performed by the Contractor in a thorough and workmanlike manner, in full accordance with the Drawings and Specifications, the City of Cabot as well as prevailing water, wastewater standards. All work shall be performed by skilled and competent workmen well experienced in water and wastewater construction methods and techniques.
- e). Any reference in these Specifications to an engineering standard (such as ASTM or AWWA) shall be to the latest version or edition as of the Bid Date. Water and Wastewater Mains are to be installed in accordance with AWWA Standards C600 for Ductile Iron Pipe, AWWA C605 for PVC pipe as applicable unless specifically provided otherwise by these specifications or by the Engineer in writing.
- f). The Contractor shall not be permitted to sublet, sell or assign this contract or sublet any of the work to be performed hereunder without the written consent of the Owner and any such assignment or subletting of any such work without said consent shall be null and void and without force and effect. The Owner shall have the right to assign in whole or in part its rights hereunder.
- g). CONTRACTOR is an "Independent CONTRACTOR" and has full power and authority to select the means, methods, and manner of performing the work, subject to strict compliance with requirements of local authorities, being responsible to CWW for all materials delivered and for the results herein contracted for, and, upon completion of the contract, the work shall be delivered complete and undamaged in accordance with the specifications and plans.
- h). CONTRACTOR shall not be permitted to sublet, sell or assign this contract or sublet any of the work to be performed hereunder without the written consent of CWW and any such assignment or subletting of any such work without said consent shall be null and void and without force and effect. CWW shall have the right to assign in whole or in part its rights hereunder.

Cabot WaterWorks Standard Construction Specifications

- i). CONTRACTOR shall prosecute the construction of said work with due diligence and at such a rate and in such manner as in the opinion of the Engineer is necessary for completion within a reasonable time. CONTRACTOR shall not open up work to the prejudice of work already started and shall arrange its work and dispose of materials so as to insure the least possible interference and inconvenience to the land owners on or beside whose property the pipelines are being constructed or to the public where the pipelines lie in or near a public thoroughfare. CONTRACTOR shall employ such number of construction crews as are reasonably necessary to construct said pipelines within the allotted time, provided CWW may require the employment of an additional crew or crews, if in its judgment it is necessary, in order to complete said pipelines within the time required.
- j). The Contractor shall prosecute the construction of said work with due diligence and at such a rate and in such manner as in the opinion of the Engineer is necessary for completion within a reasonable time. The Contractor shall not open up work to the prejudice of work already started and shall arrange its work and dispose of materials so as to insure the least possible interference and inconvenience to the land owners on or beside whose property the pipelines are being constructed or to the public where the pipelines lie in or near a public thoroughfare.
- k). Contractor shall employ such number of construction crews as are necessary to construct said project within the allotted time provided the Owner may require the employment of an additional crew or crews, if in its judgment it is necessary, in order to complete said project within the time required.
- l). The CONTRACTOR shall clear the pipeline right-of-way; remove pavement as may be necessary; excavate the trench and pits to the required dimensions; construct and maintain all approaches required for traffic control; sheet, brace, and support adjoining ground or structures where necessary; handle all drainage or ground water; guard the site; load, unload, haul, distribute, lay and test the pipes, fittings, valves, hydrants, and appurtenances; rearrange branch connections to main sewers, conduits, ducts, culverts, or pipes where necessary; replace all damaged drains, sewers, culverts, or other structures; backfill the trench and pits; restore the roadway surface unless otherwise stipulated; remove surplus excavated material; clean the site of the work; and maintain the street or other surface over the trench until final acceptance of the completed project.
- m). All materials furnished by CONTRACTOR are subject to approval by the Engineer as to quality and suitability for the construction to be performed.
- n). All work is to be performed with diligence in a workmanlike manner according to best practices so as to produce a completed job of a quality commensurate with prevailing standards of the water and wastewater industry and CWW particularly.
- o). CONTRACTOR at all times shall have a Superintendent as its agent of the work. Such Superintendent shall have full authority to execute the orders, or directions, of the Engineer without delay; shall apply promptly such materials, tools, equipment and labor as may be required; same shall be furnished irrespective of the amount of work sublet; and shall not be removed from the work, or replaced, without written permission by the Engineer.
- p). Except in instances where common labor may be utilized, CONTRACTOR shall employ only competent, experienced, and skilled workman to do the work, and all work shall be performed and completed in good, careful, and workmanlike manner and to the satisfaction of CWW. CWW shall have the right at all times to require the removal of any superintendent, foreman or workman for performing inferior work.
- q). The methods, equipment and appliances shall produce a satisfactory quality of work and shall be adequate to maintain the schedule of progress as submitted under provisions herein above. CONTRACTOR shall maintain all equipment in good repair to insure efficient performance of the work required. The Engineer shall have the right to require the removal and/or replacement of any equipment which he deems incapable of satisfactory performance.

1.5 SUBMITTALS

- a). Submit Material Manufacturers literature and recommended application procedures for each product to be used.
- b). No Material or product shall be installed prior to approval from Cabot Waterworks.

1.6 PERMIT(S)

- a). The Contractor shall be responsible for securing any required permit for the construction of the Project except for state highway permits. Permits that may be required include but are not limited to construction access, blasting permits and bonds, material storage, street department, building and storm water.
- b). Cabot WaterWorks will secure highway permits and such other permits and licenses within its jurisdiction and pertaining to occupancy and use of the facilities to be constructed.

Cabot WaterWorks Standard Construction Specifications

1.7 WRITTEN NOTICES

- a). Written notices, when required by the Contract Documents or for purposes of project administration, shall be mailed by Certified Mail, return receipt requested, as follows:
- b). If to the Owner:
Cabot WaterWorks
General Manager
PO Box 1287
One City Plaza, Suite B
Cabot, AR 72023

If to the Contractor: At the address as stated in the Agreement.

1.8 EXISTING UTILITIES AND SUBSURFACE STRUCTURES

- a). **The Contractor must comply with the ARKANSAS ONE-CALL (800-482-8998) system, and alert the Utility Systems accordingly.**
- b). The construction work encompassed in this Contract will require excavation and related activity in close proximity to existing buried utility lines and subsurface structures (and some aerial facilities). The approximate location of such utilities and structures may be shown on the Drawings, but all such utilities, structures, and individual service lines are not shown. The Contractor is to be aware of the potential for such buried utility lines and structures conflicting with his intended construction efforts, and use proper precautionary measures to locate, verify, and protect such buried lines and structures so as to avoid damage.
- c). The Contractor shall contact the owners of the various existing buried utility lines (or aerial facilities) and structures as impacted by his construction activities, and obtain their assistance in identifying, locating, and marking affected facilities prior to beginning any excavation which might endanger the existing facilities. The Contractor will bear all costs in connection with the location, marking, temporary protection, or support of such utility facilities. If such utilities are damaged or impaired due to the actions or omissions of the Contractor, then the Contractor is responsible for the cost of repairs or replacement of the affected or damaged utility lines.
- d). The Contractor shall make necessary exploratory excavations to determine the location of underground structures such as pipes, drains, conduits, and other structures.
- e). The Contractor shall provide adequate protection and support for all surface and subsurface structures or other facilities encountered during the progress of the work. Whenever such structures or facilities are in the same location as the proposed pipe line or appurtenances thereto, the Contractor shall relocate or reconstruct or cause to be relocated or reconstructed, the structure or facility to the satisfaction of the Engineer and utility facility owner. Whenever requested by the Engineer or utility owner, the Contractor shall provide drawings and other plans for supporting or otherwise safeguarding surface and subsurface structures or other facilities which in the opinion of the Engineer, or utility or facility owner, may be damaged as a result of the Contractor's work.
- f). If any utility facility or structure is damaged during the progress of the work, the Contractor shall immediately notify the appropriate owner. Repairs shall not be made by the Contractor without the prior approval of the utility facility or structure owner. The Contractor shall provide available assistance to the utility involved in making repairs under emergency conditions.
- g). The CONTRACTOR shall not operate valves in CWW' existing distribution system without approval of the ENGINEER.
- h). All existing fire hydrants and bends shall be blocked or tied in such manner so as to prevent displacement before excavating behind these appurtenances.

1.9 DAMAGE TO DISTRIBUTION and COLLECTION SYSTEM

- a). The CONTRACTOR will be held responsible for damage to CWW' distribution and collection system during the course of construction under this contract, whether by accident or carelessness.
- b). Contractor shall make immediate repairs to damages at his expense. In event service has been disrupted, immediate repair operations shall be continuous and around the clock, if necessary.
- c). Disinfection procedures when cutting into or repairing existing water mains:
 - 1.9.1.c.1. Disinfection procedures in this section are not required if repair clamps are installed while the pipe remains pressurized.
 - 1.9.1.c.2. The interior of all pipe and fittings, including couplings and sleeves shall be swabbed or sprayed with a one- percent hypochlorite solution before installation.

Cabot WaterWorks Standard Construction Specifications

1.10 WORK PERFORMED BY OWNER

- a). The intent of these specifications is for the CONTRACTOR to do all the work, including connections and repair of damage to the Distribution and Collection System in this construction contract.
- b). In emergencies, to restore service, CWW, with its labor forces, will assist the CONTRACTOR when necessary at the discretion of the ENGINEER.
- c). If CWW assists the CONTRACTOR for any reason, the CONTRACTOR shall pay for the cost of this assistance, based on the cost of labor, equipment, materials and overhead.

1.11 SAFETY REQUIREMENTS

- a). Contractor shall be totally responsible for all necessary safety measures and precautions as stipulated in the General Conditions to these Specifications, and in compliance with the Occupational Safety and Health Administration's (OSHA) Excavation and Trenching Safety standard, Title 29 of the Code of Federal Regulations (CFR), Part 1926.650 applicable to the work of the various kinds as called for under this Contract. Particular attention is called to the Appendix of these Specifications pertinent to Excavation and Trench Safety.
- b). The Contractor shall be totally responsible for providing and maintaining any necessary and required barricades, signs, markers, shoring, bracing, etc. to provide for the protection of workmen and the Owner's personnel during the duration of the Work under this Contract.

1.12 ENVIRONMENTAL ASPECTS

- a). The work shall be planned and executed in full compliance with the requirements of the Federal Environmental Protection Agency (EPA), the Arkansas Department of Environmental Quality (ADEQ), and all local authorities.
- b). Siltation Control: The work shall be so planned and executed so as to prevent siltation of area streams, ditches, swales, and drainages. Barriers and filters shall be constructed as necessary by the Contractor to intercept and impede silt or debris laden runoff from the construction site and prevent excessive quantities of silt and debris from reaching area streams and drainages. If the Contractor's construction activity involves clearing, grading, or excavation activities that result in the disturbance of one or more acres of total land area, then the Contractor shall obtain a Storm Water Permit from the Arkansas Department of Environmental Quality. The Contractor shall be responsible for any and all fees, notices, notice of intent, notice of termination, disclosure statements, storm water pollution prevention plan, etc. associated with obtaining the Storm Water Permit. Contractor shall be responsible for the cost of all claims, losses, fines, penalties, or damages charged to Owner or Engineer due to Contractor's failure to comply with the requirements of the Storm Water Permit. If requested, Contractor shall provide one copy of the storm water permit, notices, and storm water pollution prevention plan to the Engineer.
- c). Dust Control: During periods of dry, dusty conditions at the construction site, the work shall be planned and executed so as to minimize dust problems. Contractor shall provide for watering of the construction site, haul roads, and any other disturbed areas to prevent excessive dust problems within the vicinity. Water for such dust control shall be provided by the Contractor.
- d). Noise Control: The work shall be planned and executed to minimize noise on the construction site. All applicable measures for noise control as required by OSHA standards shall be used.
- e). Burning: Logs, limbs, tops, stumps, roots, and other natural debris may be burned in approved designated areas with the approval of all applicable local authorities, including adjacent land owners, the local Fire Department, and the City of Cabot. All state and local laws pertaining to controlled burning must be followed. No burning shall occur in a maintained landscape. No scrap paper, cans, scrap pipe, etc. may be burned. If the Contractor is not allowed to burn the above mentioned items, then all debris from clearing operations shall be hauled off-site for disposal. All trash, debris, scrap, or waste materials, resulting from construction operations will be hauled offsite for disposal. Contractor will be responsible for disposal of all such debris in an approved disposal area.

1.13 SEWAGE FLOW CONTROL AND BYPASS PUMPING

- a). Sewage flows in pipelines under construction shall be reduced to an acceptable level through plugging, blocking and bypass pumping of the flows.
- b). When the sewage flow is blocked or plugged, sufficient precautions shall be taken to protect the public health and protect sewer lines from damage. No sewage shall be allowed to backup into any homes or building. No sewage shall overflow any manhole, cleanout, or any other sewer access. Users upstream of the replacement area shall be able to use all of their water and sewer utilities without interruption. During any time when an

Cabot WaterWorks Standard Construction Specifications

active sewer is plugged or blocked, the Contractor shall observe the conditions upstream of the plug and be prepared to immediately start bypass pumping if needed.

- c). When bypass pumping is required, the Contractor shall provide the necessary pumps, conduits, and other equipment to divert the flow of sewage around the section in which work is to be performed. The bypass system shall be of sufficient capacity to handle existing flow plus additional rainfall induced flow.
- d). The Contractor shall properly operate and maintain any active bypass system. Pumps and equipment shall be continuously monitored by an employee capable of starting, stopping, refueling, and maintaining the pumps during the entire period for which bypass pumping is necessary. If pumping is required on a 24 hour basis, engines shall be equipped in a manner to keep noise to a minimum.
- e). Any pump operated by the Contractor which pulls sewage or any type of material out of a manhole or sewer shall discharge this material into another manhole or appropriate container. Under no circumstances shall this material be discharged, stored, or deposited on the ground, street, road, or open environment.
- f). The Contractor shall take appropriate steps to ensure that all pumps, piping, and hoses that carry sewage are protected from traffic.
- g). The Contractor shall be responsible for having sufficient pumping capacity on site in case of an emergency, i.e. a broken water line. Under no circumstances shall groundwater, surface water, drinking water, or any other water source other than sewage be discharged into the sanitary sewer collection system.

1.14 APPLICATION FOR PAYMENT

- a). Submit an itemized list of quantities to the Engineer utilizing Unit Prices and a schedule of values in Application for Payment.
- b). Pay Periods: Calendar Month.
- c). If requested, the Contractor shall submit to the Engineer for review, a detailed schedule of construction progress indicating the sequence of work, time of starting and anticipated completion of each part, and any unusual or critical path aspects of the construction scheduling. The schedule shall include provisions for maintenance of traffic. The schedule may be of graphic form indicating time elements for the various portions of work. Revise and resubmit schedule as required.

1.15 CONFERENCES

- a). Engineer will schedule a preconstruction conference after Notice of Award. Project progress meetings will be held periodically.

1.16 QUALITY ASSURANCE

- a). **Should any work be performed without giving notice of plan of work and opportunity of inspection by Cabot Waterworks representative, the Engineer may require the Contractor to uncover such work at his own expense for examination by the Engineer. Cost of uncovering such work shall be borne by the Contractor whether or not the work is found acceptable. The work shall subject to inspection by other appropriate governmental inspectors at all times.**
- b). Maintain quality control over suppliers, manufacturers, products, services, site conditions, and workmanship to produce work of specified quality.
- c). Comply fully with manufacturer's instructions.
- d). Comply with specified standards as a minimum quality for the Work except when more stringent tolerances, codes, or specified requirements indicate higher standards or more precise workmanship.
- e). The Contractor shall supervise and direct the Work. The Contractor shall be solely responsible for the means, methods, techniques, sequences and procedures of construction. The Contractor shall employ and maintain on the Work a qualified supervisor or superintendent who shall have been designated by the Contractor as the Contractor's representative at the site. The supervisor shall have full authority to act on behalf of the Contractor and all communications given to the supervisor shall be as binding as if given to the Contractor. The supervisor shall be present on the site at all times as required to perform adequate supervision and coordination of the Work. The Owner shall have the right at all times to require the removal of any superintendent, foreman, or workman for performing inferior work.
- f). The Contractor shall furnish the Engineer with every reasonable facility for ascertaining whether the work performed is in accordance with the requirements and intent of the contract documents. If the Engineer requests it, the Contractor at any time before acceptance of the work by the Owner, shall remove or uncover such portions of the finished work as may be directed. After examination, Contractor shall restore said portions of the work to the standards required in the Contract Documents. Should the work thus exposed or examined prove to be in accordance with the Specifications, the uncovering or removing, and the replacing of the covering or making good of the parts removed shall be paid for by the Owner, but should the work so exposed or examined prove to be not in accordance with the Contract Documents, the uncovering or

Cabot WaterWorks Standard Construction Specifications

removing and the replacing of the covering or the making good of the parts removed, shall be at the Contractor's expense.

- g). The methods, equipment, and appliances shall produce a satisfactory quality of work and shall be adequate to maintain the schedule of progress. The Contractor shall maintain all equipment in good repair to insure efficient performance of the work required. The Engineer or Owner shall have the right to require the removal and/or replacement of any equipment which he deems incapable of satisfactory performance.

1.17 MAINTENANCE OF TRAFFIC

- a). The Contractor shall maintain traffic and protect the public from all damage to persons and property in accordance with all applicable State, City, and County regulations. Contractor shall conduct his operations so as to maintain and protect access, for vehicle and pedestrian traffic, to and from all properties adjoining or adjacent to those streets affected by his operations, and to subject the public to a minimum of delay and inconvenience.
- b). Suitable signs, barricades, danger lights, etc., shall be erected and the work outlined by adequate lighting at night in order to protect persons from injury and avoid property damage. The Contractor shall provide qualified flagmen to direct traffic while working upon a highway, street, or road over which traffic must pass.
- c). Traffic shall be detoured as required; however, no traffic shall be detoured without prior knowledge and approval of the traffic control agency having jurisdiction. Contractor shall notify the Owner and the City of Cabot Street Department at least 24 hours in advance of the time he proposes to detour traffic. No street shall be completely blocked, nor blocked more than one lane at any time without specific authorization. Any pavement markings damaged during the Work shall be removed and replaced promptly by the Contractor.
- d). Traffic control shall be in accordance with City of Cabot regulations and the Arkansas State Highway and Transportation Department Standard Specifications, latest edition.
- e). **Closing streets with one access route is NOT permitted.** One traffic lane shall remain open at any given time. Excavated areas within the traffic lanes of highways, streets, roads, and pedestrian walkways shall be backfilled as soon as possible and the area reopened to traffic.
- f). The Contractor shall be responsible for making provisions for the safe and free passage of persons and vehicles by, over, or around the work while it is in progress. Such provisions or traffic control plans shall be satisfactory with the Engineer, Owner, State, County, and Local authority having jurisdiction within the area of work.
- g). When required by State, County, or Local authority having jurisdiction, that traffic be maintained over any construction work in a public highway, street, or road, and such traffic cannot be maintained on the alignment of the original roadbed or pavement, the Contractor shall, at his own expense, construct and maintain a detour around the work. Such detours shall be satisfactory with the Engineer and State, County, or Local authority.
- h). The Contractor shall make the same provisions as described above for the passage of vehicular and pedestrian traffic between private property and public highways, streets, and roads that are satisfactory to the Engineer, Owner, and private property owners involved.

1.18 USE OF COMPLETED PORTIONS OF WORK

- a). The Owner may take possession of and utilize certain elements of the project as they are completed and placed into operation by the Contractor. The Contractor shall allow the Owner use of completed portions of the Work as necessary to maintain an effective system. Contractor shall plan the Work accordingly, in close coordination with the Owner so as to maintain all vital system operations.
- b). A log will be maintained by the Engineer in conjunction with the Contractor to define the precise date when the Work elements are put into use to the Owner's benefit and for the Owner's purposes. This log will establish the beginning of the warranty period for which the Contractor is responsible in accord with the General Conditions to these Specifications.
- c). Warranty requirements for elements of the Project that are not placed into active service upon completion shall be as called for in the Specifications.

1.19 REFERENCES

- a). Conform to reference standard by date of issue current as of date of Contract.
- b). The applicable codes and standards referred to in these specifications shall establish minimum requirements for materials, equipment, and installation, except where more stringent requirements are called for on the Drawings or elsewhere in the Contract Documents. Any conflict between the referenced codes and standards and the Drawings and Specifications shall be resolved by the Engineer, whose decision shall be binding upon all parties. All codes and standards referenced shall be the latest revision at the time of bidding.

Cabot WaterWorks Standard Construction Specifications

1.20 TEMPORARY ELECTRIC POWER

- a). Contractor shall provide and pay for power services required from source.

1.21 TEMPORARY WATER

- a). Contractor shall provide and pay for water, as needed, for own use.

1.22 SANITARY FACILITIES

- a). Contractor shall provide and maintain required sanitary facilities and enclosures for the appropriate handling and disposal of all human waste, solid waste, and construction waste.
- b). Maintain clean and sanitary conditions.

1.23 TEMPORARY WATER CONTROL

- a). Maintain excavations and trenches free of water. Provide and operate pumping equipment of a capacity to control water flow.
- b). Provide dewatering system and pumping to maintain excavations dry and free of water inflow on a 24 hour basis.
- c). Provide piping to handle pumping outflow to discharge in a manner to avoid erosion or deposit of silt.

1.24 TEMPORARY ACCESS ROADS AND PARKING

- a). Construct and maintain temporary construction access roads, parking areas, and detours as are required to execute the Work.

1.25 REMOVAL OF UTILITIES, FACILITIES, AND CONTROLS

- a). Remove temporary erosion control construction, temporary above grade or buried utilities, equipment, facilities, and materials, prior to Substantial Completion inspection.
- b). Remove and repair damage caused by installation or use of temporary work.

1.26 CONTRACT CLOSEOUT PROCEDURES

- a). Submit written certification that Contract Documents have been reviewed, Work has been inspected, and Work is complete in accordance with Contract Documents and ready for Engineers inspection.
- b). Submit final Application for Payment identifying total adjusted Contract Price, previous payments, and amount remaining due.

1.27 CLEANING AND DISPOSAL

- a). Maintain areas free of waste materials, debris, rocks, roots, stumps, limbs, and rubbish. Maintain site in a clean and orderly condition. No trash shall be burned or buried on the job site and shall be properly disposed of by the Contractor.
- b). Execute final cleaning prior to final inspection.
- c). Drainage ways, street surfaces and shoulders, driveways, lawns and landscaping, culverts, and all areas affected by construction shall be restored to equal or better than original condition. Ditches and drainage ways shall be left clean and unobstructed and restored to their original cross-section and grade. Culverts shall be left "open" and free-flowing.

1.28 FENCE RESTORATION

- a). The Contractor shall be responsible for maintenance of fences during construction. The Contractor shall provide as necessary temporary fencing, gates, etc., as may be required to afford access to the construction site and maintain the full integrity of the fence.
- b). All fences disturbed by construction activity shall be restored to their original condition or better using fencing materials that are of the same size, metal gauge, and character as the original fence.

2. MATERIALS APPROVED FOR CONSTRUCTION

- 2.1 All materials in contact with drinking water shall be certified as being "lead free" as determined through Section 1417 of the Safe Drinking Water Act (42 U.S.C. 300g-6) shall be certified as being in compliance with NSF/ANSI 372 or Annex G of NSF/ANSI 61. Certification shall be made by an independent agency. Self-certification by the manufacturer will not be accepted.

Cabot WaterWorks Standard Construction Specifications

- 2.2 PVC pipe shall be manufactured by a member of the Uni-Bell Plastic Pipe Association.
- 2.3 All pipe and pipe fittings furnished and installed on this project shall be inspected and tested by the manufacturer. The manufacturer shall furnish to the Engineer, prior to delivery, certificates stating that all pipe is manufactured in compliance with these Specifications. The certificate shall also fully describe the pipe proposed to be furnished.
- a). If evidence appears that all provisions of the applicable AWWA and ASTM Standards have not been complied with after the pipe has been delivered, CWW will require such field testing and sampling as necessary for certified statements of compliance to the provisions of said standards to be furnished by an approved independent laboratory. The cost for the testing and sampling or job delay will be the responsibility of the Contractor. The independent laboratory shall be one which may be chosen by the pipe manufacturer and approved by CWW.
- 2.4 **Water pipeline material shall conform to the following specifications:**
- a). **AWWA C900, DR18, PVC Pressure Pipe and Fabricated Fittings 4” through 12”.**
- b). PVC Water Pipe shall have integral bell joints with elastomeric gaskets that conform to ASTM 3212 and ASTM F477.
- c). **Ductile Iron water pipe** (flanged, mechanical joint and push-on joint) shall be bituminous coated (Asphaltic outside coating), cement lined, Pressure Class 350 conforming to **AWWA C151 & C104**. All Ductile iron pipe shall be wrapped in polyethylene encasement material in accordance with ANSI/AWWA C105/A21.5.
- d). **Polyethylene (PE)** water Pressure Pipe and Fittings 4 inch through 63 inch for Water Transmission and Distribution: AWWA C906, DR11, Pressure Class 160 PE3408, Ductile Iron OD (DIOD).
- e). Ductile Iron and Gray Iron water pipe fittings: AWWA C110/A21.10, Pressure rating 250 psi.
- f). Rubber-Gasket Joints For Ductile-Iron Pressure Pipe and Fittings: AWWA C111/A21.11
- g). Flanged Ductile-Iron Pipe with Ductile-Iron or Gray-Iron Threaded Flanges: AWWA C115/A21.11, thickness class 53, 250 psi working pressure
- h). Ductile-Iron Compact Fittings (Mechanical Joint) w/ fusion bonded epoxy coating.: AWWA C153/A21.53
- i). Double Check Detector Valve Assembly for Fire Service Backflow-Prevention: AWWA C510 w/ Detector Meter that registers the first 3 gpm of flow in accordance with AWWA M-14.
- j). Reduced Pressure Principle Detector Backflow-Prevention Assembly (RPZ): AWWA C511 w/ Detector Meter that registers the first 3 gpm of flow
- k). Air/Vacuum release valves: Acceptable Manufacturer is A.R.I. model D-025 or equal
- l). Gate Valves: AWWA C509, Resilient Seated, open left (counterclockwise) with a 2” nut, epoxy coated.
Acceptable Manufacturers are: Mueller, Clow, American Flow Control, American AVK.
- m). Fire Hydrants: AWWA C502, open left (counterclockwise) with a 1 ½” pentagon nut, 1” tall, three way outlets 2-2 ½” hose nozzles and 1-4 ¼” pumper nozzle, 5 ¼” main valve. Fire Hydrants shall be painted by the Manufacturer - **Safety Yellow**. Cabot WaterWorks will not approve field painting of Fire Hydrants.
Acceptable Manufacturers are: Mueller Super Centurion, Clow Medallion, American Flow Control ("AFC-PACER"), American AVK.
- n). Water Service Line Valves and Fittings AWWA C800
- 2.5 **Water Service Pipe and related materials shall conform to the following:**
- a). **AWWA C904, DR9, Cross-Linked Polyethylene (PEX), SDR9, Minimum Pressure Class 160, Pressure Pipe and Tubing, ½ In. Through 3 In, for Water Service.** The minimum size for water service lines for long services defined as service on the opposite side of street as water main line shall be 1.5” diameter, except on individual metered apartments. Short services defined as services on the same side of street as water main shall be a minimum of 1-inch diameter.
- b). **Tapping Sleeves:** 18-8 Type 304 Stainless Steel, Manufacturers; Ford, Mueller, Smith Blair
- c). **Service Saddles:** Brass or 18-8 Type 304 Stainless Steel, Manufacturers; Ford, Mueller, Smith Blair

Cabot WaterWorks Standard Construction Specifications

- d). **Meter Setters:** Ford Copper Meter Setters, (see Meter Setting Details)
 - e). **Meter Boxes:** Manufacturer: East Jordan Ironworks, (see Meter Setting Details)
 - f). Contact Cabot Waterworks for current water meter requirements prior to installation.
- 2.6 **Gravity Sewer Pipe and Fittings shall conform to one of the following standards:**
- a). ASTM D3034, PVC Sewer Pipe (4” through 15” diameter), SDR-26, Green Color, with a minimum Pipe Stiffness of 46 psi as determined by ASTM D2412.
 - b). ASTM F679, Standard Specification for Poly(Vinyl Chloride) (PVC) Large-Diameter Plastic Gravity Sewer Pipe and Fittings, with a minimum Pipe Stiffness of 46 psi as determined by ASTM D2412. The fittings and pipe shall be of a gasket push on joint type meeting ASTM D3212.
 - c). ASTM F794, Standard Specification for Poly(Vinyl Chloride) (PVC) Profile Gravity Sewer Pipe and Fittings Based on Controlled Inside Diameter, with a minimum Pipe Stiffness of 46 psi as determined by ASTM D2412.
 - d). ASTM F949, Standard Specification for Poly(Vinyl Chloride) (PVC) Corrugated Sewer Pipe With a Smooth Interior and Fittings, with a minimum Pipe Stiffness of 46 psi as determined by ASTM D2412.
 - e). ASTM F2736, Standard Specification for 6 to 30 in. Polypropylene (PP) Corrugated Single Wall Pipe And Double Wall Pipe, with a minimum Pipe Stiffness of 46 psi as determined by ASTM D2412.
 - f). Ductile Iron Sewer Pipe shall conform to requirements of AWWA C150 & C151 Pressure Class 350. Ductile Iron Sewer Pipe shall be internally lined with 40 mil thick coating of Protecto 401 Ceramic Epoxy. Prior to coating, the internal surface of the pipe shall be blasted with sand or grit media. The Gasket area and spigot shall be blasted and coated with 6-10 mils of Protecto 401 Joint Compound. The exterior of the pipe shall be coated with standard bituminous coated (Asphaltic outside coating) per AWWA standards. All Ductile iron pipe shall be wrapped in polyethylene encasement material in accordance with ANSI/AWWA C105/A21.5.
 - g). **All Sewer Pipe shall have integral bell joints with elastomeric gaskets that conform to ASTM 3212 and/or ASTM F477.**
- 2.7 **Sewer service pipe material shall conform to one of the following standards:**
- a). ASTM D 2665, Schedule 40 DWV or ASTM D3034, PVC Sewer Pipe, SDR-26.
 - b). Sewer **service** saddles: Acceptable Manufacturer, ROMAC Industries Style “CB” or equal.
- 2.8 **Sewer Force Main Pipe:**
- a). ASTM D2241, SDR-21 pressure rating of 200 psi. or
 - b). ASTM D1785 Schedule 40 for size 1-4” diameter or
 - c). Polyethylene (PE) Pressure Pipe and Fittings 4 inch through 63 inch for Water Transmission and Distribution: AWWA C906, DR11, Pressure Class 160 PE3408, Ductile Iron OD (DIOD).
- 2.9 **Grinder Pump Force** service pipe, Cross-Linked Polyethylene (PEX), AWWA C904, DR9, SDR9, Minimum Pressure Class 160,
- a). Air/Vacuum release valves: Acceptable Manufacturer is A.R.I. model D-025 or equal
- 2.10 All materials are subject to inspection and approval at the discretion of CWW.
- 2.11 During the process of loading or unloading, all materials shall be inspected by the CONTRACTOR for damage and any damaged material set aside.
- 2.12 Inspection of material at the manufacturer’s plant, at the point of delivery, on the job site, or in place shall not relieve the CONTRACTOR of his responsibility and the material may be subject to rejection until final acceptance of the completed project by CWW.
- 2.13 **HANDLING PIPELINE MATERIALS**
- a). The CONTRACTOR shall handle the material with the utmost care and in a manner to prevent damage to the materials, material coating and lining during loading, hauling, unloading, and installation operations. Pipe and fittings shall not be dragged along the ground or dropped and shall be stored so as to protect all materials from damage. Material damaged shall be replaced or repaired at the CONTRACTOR'S **expense**.
 - b). Hooks shall not be in contact with the pipe interior.
 - c). The interior of the pipeline materials shall be kept free from dirt and foreign matter at all times.
 - d). Pipeline materials, especially valves, hydrants and fittings shall be drained and stored in a manner to protect them from damage by freezing.

Cabot WaterWorks Standard Construction Specifications

3. PROTECTION OF VEGETATION

- 3.1 The CONTRACTOR shall not remove or disturb any vegetation except that required for execution of the work.
- 3.2 Unless otherwise directed in these specifications or Plans, the CONTRACTOR shall replace all sod, shrubbery, trees, and flowers disturbed or removed, that are located upon public and private property. The CONTRACTOR shall replace vegetation with healthy vegetation of the same kind or type and re-landscape or cause such to be performed throughout the work area as soon as possible after the pipelines and appurtenances have been installed. All vegetation shall be replanted in the original location. The CONTRACTOR shall maintain all replanted vegetation by the application of water, fertilizers and top soil. The vegetation shall be cultivated to prohibit the growth of foreign vegetation until a well developed root system has been established and transplanted vegetation has overcome the "shock" resulting from transplanting. All vegetation which dies or becomes unhealthy shall be replaced by the CONTRACTOR. The contour of the ground shall be left as near the original contour as possible.
- 3.3 The CONTRACTOR shall restore the topography of the work site to facilitate proper drainage of all adjacent lands.
- 3.4 The CONTRACTOR shall stabilize all areas where ground surface has been disturbed and erosion is likely to occur in accordance with the approved Storm Water Pollution Prevention Plan (SWPPP). The method of stabilization shall be approved by CWW.
- 3.5 In developed and undeveloped areas, vegetation shall be re-established in all disturbed areas by seeding and mulching, or by sodding as directed by the ENGINEER.
 - a). Prior to seeding or sodding, noxious weeds and Johnson grass shall be grubbed, and raked. The collected material shall be removed from the site. The surface shall be cleared of stumps, loose surface rocks larger than ¾", roots, trash and debris that might hinder grass mowing.
 - b). The CONTRACTOR shall provide high quality topsoil with no rocks or noxious weeds. The topsoil shall be approved by the ENGINEER prior to application.
 - c). Thickness of topsoil shall be a minimum three (3").
 - d). The CONTRACTOR shall prepare a loose surface seed bed 2" in depth in the area of replacement.
 - e). Areas to be seeded and mulched shall be accomplished by seeding with permanent lawn grasses. Seed shall comply with the current rules and regulations of the Arkansas State Plant Board and the germination test shall be valid on the date the seed is used. It shall have a minimum of 98% pure seed and 85% germination by weight, and shall contain no more than 1% weed seeds. Do not use FESCUE or WHEAT seed. Seed shall be placed on a loose surface seedbed. Fertilizer (equivalent analysis 10-20-10) shall be applied to these areas at the rate of 250 lbs. per acre. Grass mixture shall be as approved by CWW. SEEDING AND MULCH SHALL BE OF THE HYDRO-SEEDING METHOD. Mulch shall be finely chopped. Mulch cover shall consist of; straw from threshed rice, oats, wheat, barley, or rye; wood excelsior; hay obtained from various legumes or grasses, such as lespedeza, clover, vetch, soybeans, bermuda, carpet sedge, bahia, fescue, or other legumes or grasses; or a combination thereof. Mulch shall be dry and reasonably free from Johnson grass or other noxious weeds, and shall not be excessively brittle or in an advanced state of decomposition. Mulch shall be applied at the rate of 3000 lbs. per acre. Tackifiers used in mulch anchoring shall be of such quality that the mulch cover will be bound together to form a cover mat that will stay intact.
 - f). The Contractor shall replace seed and mulch that has eroded or failed to germinate until the ground has "established" vegetation.
 - g). Property with existing sod shall be re-sodded. New sod shall be of the same species as existing turf.
- 3.6 Ornamental trees and shrubs having a diameter of two inches (2") or less (measured 6-inches from the ground) shall be removed and replaced. The CONTRACTOR shall hand dig around the tree or shrub to be replaced. The entire root system shall be removed (minimum 2-foot diameter root ball), wrapped in burlap, moistened and protected.
 - a). The CONTRACTOR shall replant/replace any tree or shrub removed within 48-hours of removal.
 - b). A hole shall be excavated sufficient to accommodate the entire root system. The hole shall be filled with rich topsoil. This material shall be compacted below and around the root system.
 - c). Trees or shrubs shall be guaranteed to live for one year after being replanted or replaced. Dead or dying trees or shrubs shall be replaced within thirty (30) days of written notification at the CONTRACTOR'S expense.

Cabot WaterWorks Standard Construction Specifications

- d). The CONTRACTOR shall thoroughly water all planted and sodded areas and maintain them by application of additional water and additional fertilizer until an average of 80% of the ground has "established" vegetation.
- e). Restoration of permanent summer lawn grass will be considered complete when the grass has a well-developed root system showing vigorous runners in all directions and blending with the undisturbed grass adjacent to the area being re-established.
- f). CWW will furnish metered water necessary for the establishment of vegetation.
- g). Backflow Preventers shall be furnished and installed by CWW between the water source and the hose to be used. Removal or relocation of the Backflow Preventer(s) is prohibited.
- h). All lawns and maintained grass areas, pastures and meadows, and wooded areas disturbed by construction shall be restored to a condition equal to or better than that existing prior to construction. In general, all surfaces shall be graded smooth and shall be free of rock larger than ¾", clumps, sticks, trash and debris. Wooded areas cleared and grubbed of trees shall be only seeded and mulch unless otherwise directed by the ENGINEER.
- i). Sodding and seeding work shall commence within one month of the installation of pipeline segment. Transplantation of vegetation shall be immediate after installation of pipe.
- j). Failure to begin vegetation restoration in a timely manner or failure to complete vegetation restoration to the satisfaction of the property owner and ENGINEER shall result in CWW securing a licensed landscaping service to perform the work. The cost of the landscaping work will be deducted from monies due the CONTRACTOR.
- k). The CONTRACTOR shall use suitable equipment for fine grading and landscape work. Heavy equipment normally associated with utility work is not deemed satisfactory. Equipment of the size and nature normally associated with landscape work shall be used.
- l). All other work associated with the restoration of vegetation shall be subsidiary to the various pay items and will not be paid for separately.

4. LOCATION, ALIGNMENT and GRADE

- 4.1 All work shall be constructed in accordance with the lines and grades shown on the Drawings. Elevations of existing ground, structures, and appurtenances, and existing utilities are believed to be reasonably correct as shown but are not guaranteed to be absolute and therefore are presented only as an approximation. Any error or apparent discrepancy in the data shown or omissions of data required for accurately locating the work shall be referred immediately to the Owner for interpretation or correction.
- 4.2 The Contractor is responsible for all construction layout, both horizontal and vertical control of pipelines and appurtenances. Horizontal and vertical control points shall be established along or adjacent to the construction area. It shall be the responsibility of the CONTRACTOR to make necessary measurements from control points in order to maintain the proper alignment and grade of the pipelines and appurtenances.
- 4.3 The Contractor shall be responsible for resetting all property pins disturbed by construction activities.
- 4.4 The Contractor shall carefully preserve bench marks, reference points and stakes and in case of willful or careless destruction, the Contractor shall be charged with the resulting expense and shall be responsible for any mistakes that may be caused by their unnecessary loss or disturbance.
- 4.5 Pipe, fittings, valves and hydrants shall be located and maintained to conform closely to the location, lines and grades specified hereunder or as shown on the Plans, whichever is more stringent.
- 4.6 Water and wastewater pipe alignment shall be located:
 - a). Within utility easements where provided. Where no easements mains shall be installed within the outer 4' of street or highway right-of-way.
 - b). Water and wastewater mains shall typically be installed on opposite sides of streets.
 - c). Water and wastewater mains shall have a minimum clearance of 3' (feet) from all other utilities.
 - d). CWW shall approve alignment and grade of water and wastewater mains prior to construction.
 - e). **Water Mains shall be installed with 3' minimum and 4' maximum cover below final grade.**

Cabot WaterWorks Standard Construction Specifications

- f). Main line resilient seated gate valves of the same diameter as the pipe shall be installed on both sides of connections to lateral water mains and every 1200' along water mains, typically at locations where fire hydrants are installed. Gate valves shall be installed on all lateral water mains within 10 feet of connection to mains.
- g). Fire Hydrants shall be installed at a maximum spacing of every 600' along water mains and at intersections to side streets.
- h). Valves and hydrants shall be set with operating stem and nut plumb. There shall be no sharp and sudden breaks, requiring extra fittings and no joint shall be located underneath a sub-structure without the consent of the ENGINEER.
- i). **Sanitary hazards:** Water mains and sanitary sewers shall be constructed as far apart as practicable, and shall be separated by undisturbed and compacted earth. A minimum horizontal distance of ten feet should be maintained between water lines and sewer lines or other sources of contamination. Water lines and sewers shall not be laid in the same trench except on the written approval of the Arkansas Department of Health. Water mains necessarily in close proximity to sewers must be placed so that the bottom of the water line will be at least 18 inches above the top of the sewer line at its highest point. If this distance must unavoidably be reduced, the water line or the sewer line must be encased in watertight pipe with sealed watertight ends extending at least ten feet either side of the crossing. Any joint in the encasement pipe is to be mechanically restrained. The encasement pipe shall be vented to the surface if carrying water or sewer under pressure. Where a water line must unavoidably pass beneath the sewer line, at least 18 inches of separation must be maintained between the outside of the two pipes in addition to the preceding encasement requirement. Exceptions to this must be approved in writing by the Arkansas Department of Health.

5. PIPE TRENCH CONSTRUCTION Water & Wastewater

- 5.1 All water and wastewater pipes, (Ductile Iron and PVC) shall be bedded in accordance with Specifications for PIPE BEDDING & BACKFILL.
- 5.2 Unless bound herein or shown on the Plans, information related to soil conditions is not furnished by CWW. Any information furnished by CWW related to soil conditions is not guaranteed to represent actual conditions which the CONTRACTOR will encounter and is to be used at the CONTRACTOR'S risk; therefore, the CONTRACTOR shall take whatever action he feels necessary to satisfy himself as to the actual subsurface soil conditions.
- 5.3 The trench shall be excavated to the alignment and grade specified and only so far in advance of pipe installation as the ENGINEER shall permit. Trenches along public streets or roads shall be limited to 300 feet or less, or as permitted by the governmental authority having jurisdiction. This limit may be reduced by the ENGINEER in congested areas.
 - a). The use of trench-digging machinery will be permitted except in places where operations of same will cause damage to trees, buildings, or other existing facilities above or below the ground; in which case hand methods shall be employed.
 - b). CONTRACTOR shall remove the minimum amount of street, driveway, sidewalk, parking lot, or other pavement required to permit installation of the pipelines or appurtenances. All pavement surfaces shall be saw-cut in straight lines with suitable equipment before removal. Concrete surfaces shall be scored with a suitable concrete saw unless all material is removed between existing construction joints.
- 5.4 Blasting for excavation will be permitted only after the CONTRACTOR secures the approval of the ENGINEER and only when proper precautions are taken for the protection of persons and property. The hours of blasting will be fixed by the ENGINEER. Any damage caused by blasting shall be repaired by the CONTRACTOR at his expense. The method of transporting, handling, and storage of explosives and blasting procedure shall conform to Federal Regulations, local and state laws and municipal ordinances.
- 5.5 Excavation Safety
 - a). Whenever necessary to prevent caving; excavations in sand, gravel, sandy soil, or other unstable material shall be adequately sloped, shored and/or braced in accordance with OSHA 29 CFR 1926.650 SUBPART-P.
 - b). **29CFR 1926.652** - Each employee in an excavation shall be protected from cave-ins by an adequate protective system designed in accordance with 29 CFR 1926.650 except when:
 - Excavations are made entirely in stable rock; or

Cabot WaterWorks Standard Construction Specifications

- Excavations are less than 5 feet (1.52 m) in depth and examination of the ground by a competent person provides no indication of a potential cave-in.
- 5.6 Where shoring and bracing is used, the trench width may be increased accordingly. Trench shoring shall remain in place until the pipe has been installed and jointed. Where slides or cave-ins occur, the CONTRACTOR shall, at his expense, provide proper bedding and support for the pipe.
- 5.7 The trench width may vary and depend upon the depth and the nature of the excavated material encountered. The trench shall be of ample width to permit the pipe to be laid and joined properly and the backfill to be placed and compacted properly.
- 5.8 The minimum width of trench shall be:
- a). **12" plus the nominal pipe diameter for pipe up to 24-inches in diameter;**
 - b). 18" plus the nominal pipe diameter for pipe over 24-inches in diameter.
- 5.9 The trench shall be excavated to a depth that accommodates a minimum **3' (feet) of cover** measured from top of pipe to finished grade plus undercut as required where the following conditions exist:
- a). When ledge rock, boulders, large stones, and other rock formations are encountered, all rock shall be removed to provide a clearance of at least 6" (inches) below and sides of pipe, valves, and fittings.
 - b). 9" inches when Type 5 Bedding is required.
 - c). 9" inches for pipelines and appurtenances larger than 24-inches in diameter.
 - d). Where the bottom of the trench at sub-grade is found to be unstable or to include ashes, cinders, refuse, vegetable or other organic material, or large pieces of inorganic material, that, in the judgment of the ENGINEER, should be removed, the CONTRACTOR shall remove all such material to the extent required by the ENGINEER.
- 5.10 All excavated material shall be stockpiled in a manner that will not endanger the work and that will not obstruct streets, sidewalks and driveways. Excavated material that is acceptable for backfill shall be separated from the general excavation material. Excess or unsuitable material and debris shall be removed promptly. Gutters and ditches shall be kept clear or other satisfactory provisions shall be made for drainage.

6. PIPE BEDDING & BACKFILL Water & Wastewater

- 6.1 CONTRACTOR shall bed all pipe in accordance with Type 4 or Type 5 bedding details below.
- a). Type 4 Bedding is required on all water and sewer pipelines.
 - b). Type 5 Bedding shall be required at any street, road, or ally crossing.
 - c). State Highway crossings shall be performed by tunneling and/or boring in accordance with Section 0.
- 6.2 **All pipe bedding shall be inspected by CWW' representative before backfilling.**
- 6.3 All bedding shall provide a uniform and continuous support for the pipe barrel. A shallow depression shall be made in the bedding to accommodate bell ends.
- 6.4 If the pipe trench passes over previous excavations, the trench bottom shall be compacted to provide the same bearing capacity as adjoining undisturbed native soil.
- 6.5 All trenches shall be backfilled as soon as possible after installation of pipe and appurtenances. In areas with concrete blocking, it may be necessary to backfill only a portion of the trench in order to allow placement and curing of concrete. Fittings or appurtenances designated by the ENGINEER shall not be backfilled until the hydrostatic pressure and leakage tests have been completed.
- 6.6 Compressible silts, clays and Dona-fill shall not be used for pipe bedding and backfill.

Cabot WaterWorks Standard Construction Specifications

6.7 TYPE 4 BEDDING shall consist of select granular material as specified in ASTM D2321, Class IA.

- a). **Select Granular Bedding Material** –shall conform to the following grading by weight:

ASTM D2321, Class IA (Angular crushed stone or gravel)

SIEVE SIZE	PERCENT PASSING
1.5"	100%
#4	< or = 10%
#200	< 5%

- b). Select Granular Bedding Material shall be placed to provide a 6” bedding layer under the pipe and carefully tamped and rammed around the pipe until the aggregate has been brought to 6” above the top of the pipe.
- c). The remaining trench may be backfilled with native material, except rocks larger than six (6) inches will not be permitted. Upon reaching the top of the trench with backfill, the trench shall be rolled by passing the wheel or track of heavy equipment along the trench line to attain consolidation.
- d). In areas where sod, trees, shrubs, flowers or other vegetation has been removed and is to be replanted, the top six (6) inches of backfill shall be of suitable top soil.

6.8 TYPE 5 BEDDING

- a). Select Granular Bedding Material shall be deposited to provide a 9” layer under the pipe and carefully tamped and rammed around the pipe until the aggregate has been brought to 6” above the top of the pipe. Where the soil in the bottom of the trench is wet or soft enough to intrude into the voids of granular material, coarse sand shall be used for bedding.
- b). After aggregate has been brought to 6” above the top of the pipe, compaction shall continue until 90% of maximum density as determined by the Modified Proctor Compaction Test has been achieved.
- c). When pipe trenches cross or roads, streets, alleys, sidewalks, driveways, parking lots, or other areas specified, the backfill shall be continued using the Select Granular Bedding Material, and shall be compacted to 95% of maximum density as determined by the Modified Proctor Compaction Test to a point 9" below the bottom of the improved surface. As an alternate, the trench from 6" inches above the pipe to 9" below the bottom of the improved surface may be filled with a soil-cement mixture or a mixture of flyash-bottom ash, which has been approved by the ENGINEER in advance. The top 9” of backfill shall consist of pavement repair conforming to the detail for Type 5 bedding below.

- 6.9 The CONTRACTOR shall fill trenches with suitable material where settlement has occurred throughout the warranty period after completion of the project.

Cabot WaterWorks Standard Construction Specifications

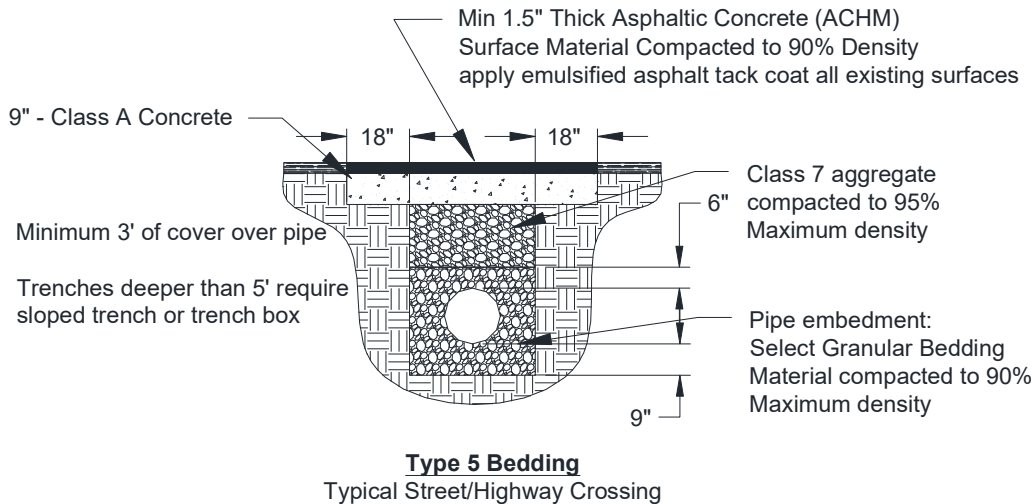
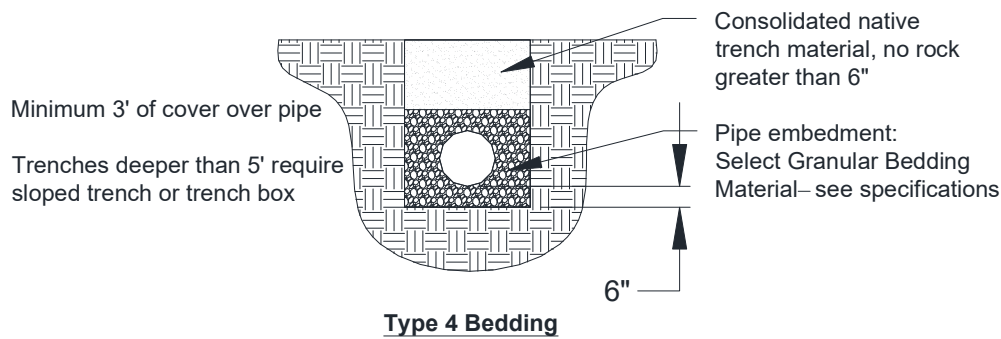

7. PIPE INSTALLATION – GENERAL Water & Wastewater

- 7.1 The Contractor shall notify the Engineer or his representative 24 hours prior to trenching to schedule inspection of all pipe installed. Pipe bedding shall be inspected by CWW' representative prior to backfilling.
- 7.2 Proper implements, tools and equipment shall be provided and used by the CONTRACTOR for the safe and convenient prosecution of the work. Under no circumstances shall pipe or accessories be dropped or dumped into the trench.
- 7.3 **All foreign matter or dirt shall be removed from the inside of the pipe and appurtenances before lowering into the trench and the pipe interior shall be kept clean during and after installation. A swab shall be kept in the pipelines as long as the pipe is being laid.**
- 7.4 **When pipe installation is not in progress, the open ends of the pipe shall be sealed by installing a plug or cap of sufficient design to prevent storm water, foreign matter, and dirt from entering the pipeline.**
- 7.5 Cutting of the pipe for inserting into valves, fittings or closure pieces shall be done in a neat and workmanlike manner without damage to the pipe or pipe lining. Torch cutting is not permitted. Pipe inserted into valves, fittings or closure pieces shall be **cut at an angle of 90° to the pipe centerline.** Cutting at other angles to provide greater deflections at the joints shall not be permitted. Field welding or welding except by the pipe manufacturer shall not be permitted.
- 7.6 Pipe shall be laid with bell ends facing the direction of installation; and for lines on an appreciable slope, bells shall, at the direction of the ENGINEER, face upgrade.
- 7.7 No pipe shall be laid in water, or when the trench condition or the weather is unsuitable for such work, except by permission of the ENGINEER. Contractor shall dewater open trenches as required prior for pipe installation.
- 7.8 **Tracer Wire:** A continuous 12-gauge copper wire (insulation color blue for water and green for sewer), shall be installed with all pipe including service lines. The wire shall be installed directly on TOP of the pipe after initial backfill. The wire shall be looped up to the top of valve boxes, and around valves and other appurtenances in such manner that there is no interference with the operation of the valve or appurtenance.

Cabot WaterWorks Standard Construction Specifications

- a). When the pipe is cut, the plain ends must be beveled similar to the original manufacturer's bevel on full lengths. After beveling, stop marks must be applied to the ends. Use the plain end of another piece of pipe or fitting to determine the location of the stop mark and mark the piece of pipe that has been cut. The pipe shall be pushed into bell or coupling either by hand or with the use of lever and block. Care shall be exercised to assure that the pipe is not damaged by the application of levers. Suitable wood blocks shall be used between levers and the pipe as shown below.
- 8.5 The beveled end shall be forced inside the gasket and bell until it strikes the end of the interior of the bell, after which the end of the pipe shall be moved sideways or up eight (8") inches to move it slightly away from home to allow for expansion and to provide flexibility to the completed line. The pipe may then be deflected as prescribed in the preceding table.

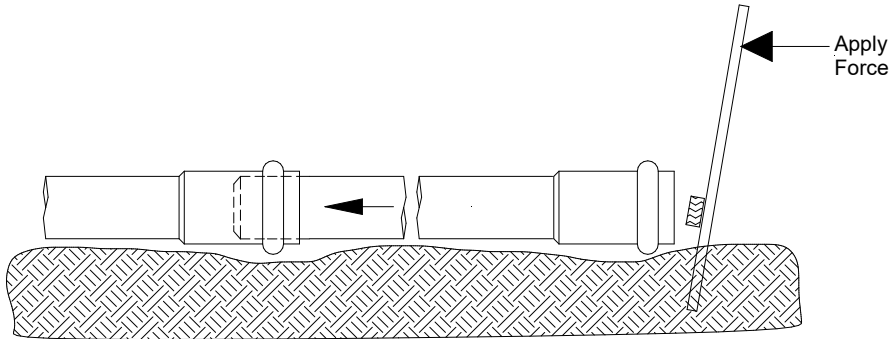

- 8.6 During the pipe laying operation, deflections at joints shall not exceed the amounts indicated in the following tables for the various types of joints and pipe.
- 8.7 PVC pressure pipe joint deflection may be achieved by following the procedure and limits, as defined:
- Keeping pipe length in straight alignment with the previously laid length, insert spigot end into the bell gasket until the reference mark is flush with the leading edge of the bell lip.
 - Move to opposite end of the pipe and manually offset the pipe to the recommended offset. A block and bar may be used on heavier diameter pipe to provide continually controlled movement. Never use excavation equipment to obtain offset.
 - Partially backfill installed pipe length to secure placement.
 - If additional deflection is required, proceed from sequence 1, on next pipe length.
 - Caution:** Over insertion of spigot end and/or exceeding the recommended offset may create material stress at joint assembly. PVC fittings shall be used to achieve greater offsets.

MECHANICAL JOINT PIPE (Ductile Iron Pipe)

<u>Size of Pipe</u>	<u>Degrees</u>	<u>Maximum Offset (inches)</u>	
		<u>18' Joint</u>	<u>20' Joint</u>
4"- 6"	7°	27"	30"
8"- 10"- 12"	5°	20"	22"
14"- 16"- 18"- 20"	3°	11"	12"

PUSH-ON JOINT PIPE (Ductile Iron Pipe)

<u>Size of Pipe</u>	<u>Degrees</u>	<u>Maximum Offset (inches)</u>	
		<u>18' Joint</u>	<u>20' Joint</u>
4"- 6"- 8"- 12"	5°	19"	21"
14"- 16"- 20"- 24"- 36"	3°	11"	12"

PUSH-ON PVC PIPE

<u>Size of Pipe</u>	<u>Degrees</u>	<u>Maximum Offset (inches)</u>	
		<u>20' Joint</u>	<u>Radius</u>
4"- 6"- 8"- 12"	3°	8"	573'
14"- 16"- 20"- 24"- 36"	1.5°	6"	764'

Cabot WaterWorks Standard Construction Specifications

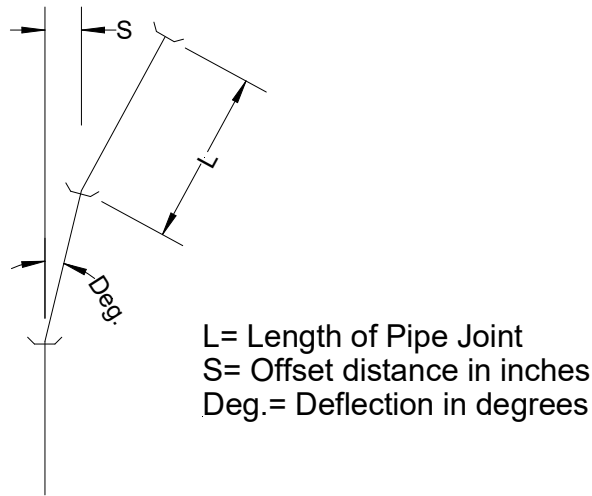

9. MECHANICAL JOINT & RESTRAINED JOINT PIPE & FITTINGS

- 9.1 All pipe shall be restrained where elbows or valves are installed and at deadends.
- 9.2 Beveled pipe ends shall be cut off for joining mechanical joint & restrained joint fittings
- 9.3 Prior to joining pipe and/or fittings, the plain ends of the pipe and the bells of the pipe or fittings shall be thoroughly cleaned, removing all foreign materials from the bells, especially the gasket seats.
- 9.4 The gland rings shall be placed on the plain end of the pipe or fittings, followed by the rubber gasket which has been thoroughly cleaned and lubricated.
- 9.5 The plain end of the pipe shall be placed in the bell, to which connection is to be made, and shouldered in back of the bell. The rubber gasket shall be advanced into the bell and seated in the gasket seat; next the gland ring shall be brought into contact with the gasket, and all bolts entered and nuts started. The pipe may then be given a maximum deflection as prescribed in the preceding table.
- 9.6 Joints shall be made tight by advancing the nuts with a wrench in an alternating pattern until a tight joint is made.
- 9.7 The CONTRACTOR shall provide a "torque wrench" suitable for measuring tension on bolts for at least such a time as the workmen making the joints have gotten the "feel" of the required tension. At no time should handles longer than those supplied by the wrench manufacturer be permitted. The fitting manufacturer's recommended torque range shall be used. If recommended bolt torques are not provided by the manufacturer use the following torque ranges may be used:

5/8" Bolts	45- 60 ft. lbs.
3/4" Bolts	75- 90 ft. lbs.
1" Bolts	85-100 ft. lbs.
1 1/4" Bolts	105-120 ft. lbs.
- 9.8 After the workmen have become accustomed to this torque, a socket wrench with a maximum 10-inch handle may be used.
- 9.9 The rubber gasket and joint bolts of mechanical joint restraint glands shall be installed in accordance with above. Set bolts shall be tightened in an alternating pattern evenly to the manufacturers recommended torque.
- 9.10 The retainer gland and all bolts shall be encased in polyethylene material in accordance with Section 19.

Cabot WaterWorks Standard Construction Specifications

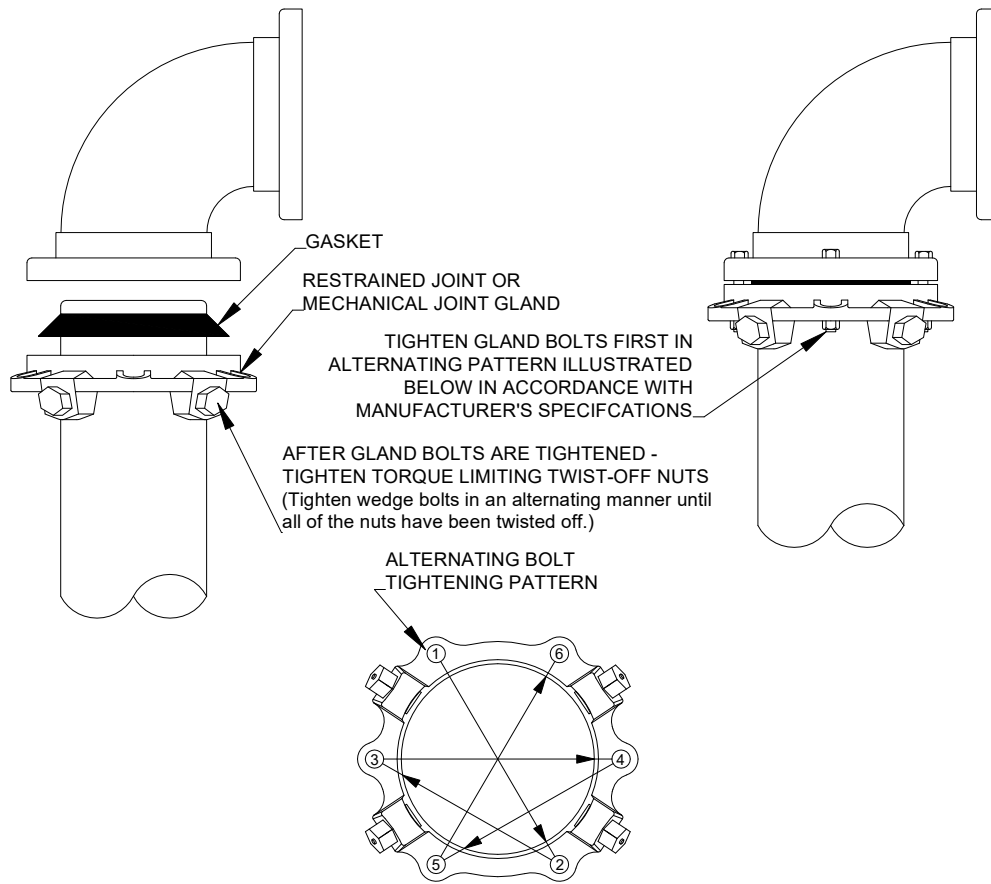

Mechanical Joint & Restrained Joint Connections

10. JOINTING FLANGED PIPE & FITTINGS

- 10.1 The faces of all flanges shall be thoroughly cleaned and all burrs or imperfections removed and brushed with a steel brush.
- 10.2 Gaskets between flanges shall be rubber or asbestos of 1/16-inch minimum thickness.
- 10.3 Care shall be taken to prevent strain of the flanges. All bolts and nuts shall be cleaned and lubricated prior to tightening. Bolts on opposite sides shall be tightened alternately to the torque listed in paragraph 9.7 herein.

11. JOINTING POLYETHYLENE (PE) PIPE

- 11.1 PE pipe shall be joined by fusion, mechanical or flange adapter. The joining method used shall provide full thrust restraint for the pressure class of the pipe.
- 11.2 Cabot WaterWorks shall approve the joining material prior to construction.

12. JOINTING ASBESTOS-CEMENT PIPE

- 12.1 Couplings shall be approved in advance for connection to asbestos-cement pipe. Couplings shall utilize a compression gasket. Striking the coupling or pipe with a hammer or other heavy object will not be permitted.
- 12.2 After the joint has been assembled, check the entire circumference of the coupling to assure that the gasket does not leak.

13. VALVE INSTALLATION

- 13.1 Valves shall be jointed in accordance with the methods of mechanical joint pipe as specified herein. Valve stems shall be plumb and there shall not be any obstructions which will prohibit the installation of valve boxes

Cabot WaterWorks Standard Construction Specifications

directly over the stem. Concrete anchor collars shall be provided around an adjoining length of pipe for all valves 16-inches in diameter or larger and for smaller valves when specified on the Plans. Mechanical joint retainer glands shall be installed on all valves with mechanical joint ends 12-inches in diameter or larger when ductile iron pipe is specified and for smaller valves when specified. All valves shall be firmly supported on well compacted soil.

- 13.2 Pipe shall be inserted as far as possible on each side of valves that are inserted in the line.
- 13.3 VALVE BOXES: Ferrous Cast Iron, 2 piece, screw type valve box assembly, 5 1/4" shaft with a cast iron lid shall be installed over all valves. The Cast Iron lid shall have "WATER" or "SEWER" cast into the lid with raised letters for water valves and sewer valves respectively. The Cast Iron lid shall seat flush with the top of the valve box. The valve box shall extend above grade at all times until completion of building construction and final grading. Valve boxes shall be installed over the operating nut of each valve and be of adequate length to reach the finished ground or paved surface. Boxes shall be firmly supported, plumb and centered over the valve operating nut using a valve box centering device. No part of the box shall rest on the valve, (See Valve installation detail below).

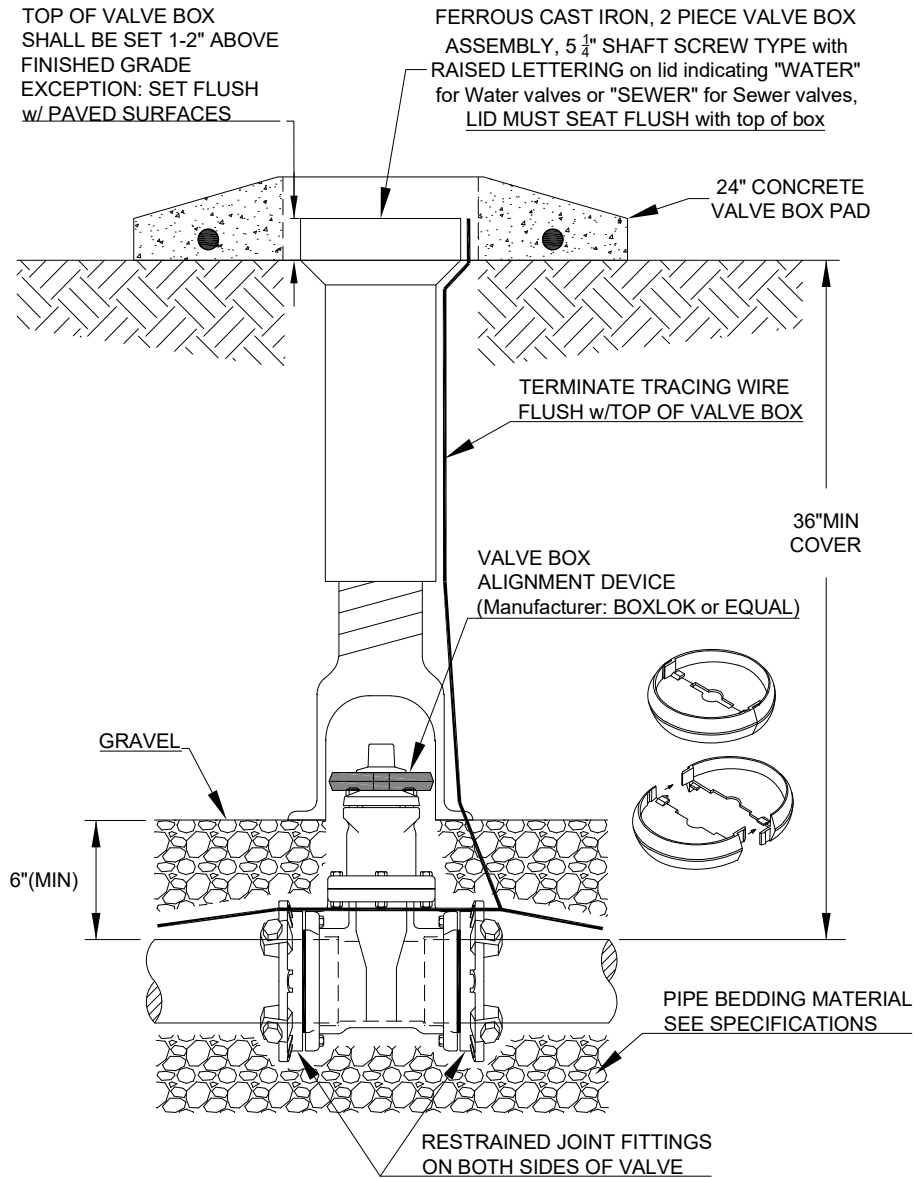

VALVE INSTALLATION DETAIL

Cabot WaterWorks Standard Construction Specifications

14. TAPPING SLEEVE & TAPPING SADDLES

- 14.1 The Contractor shall notify CWW' representative 24 hours prior to connecting to CWW' distribution system. CWW representative shall be present to observe the pipeline tap and witness the tap coupon retrieval.
- 14.2 The CONTRACTOR shall excavate and install tapping sleeves, tapping valves and tap machine as required.
- 14.3 The pipe shall be free of dirt and other debris and shall have a smooth surface before attaching tapping sleeve or tapping saddle. All rough areas on the pipe barrel shall be smoothed.
- 14.4 Tapping saddles or sleeves shall be bolted securely to the pipe. The face of the outlet shall be plumb. Tapping sleeves shall be installed in accordance with manufacturer's procedures. Bolts for tapping saddles shall be alternately tightened "snug" and then alternately tightened to a torque of 100-foot pounds minimum.
- 14.5 The tapping valve shall be bolted securely to the tapping sleeve or tapping saddle outlet flange. The tapping machine shall be bolted securely to the valve.
- 14.6 After installation of the tapping sleeve or saddle and the tapping valve, and before drilling through the pipe, the sleeve or saddle shall be hydro-statically pressure tested at 150psi with an approved test pump connected to the test port on the sleeve or saddle.
- 14.7 The pilot drill and shell cutter shall be in good condition. The shell cutter shall be the size required to cut the full opening specified.
- 14.8 Only qualified operators shall operate the tapping machine. The "coupon" shall be withdrawn. Care shall be exercised to avoid drilling or cutting the back side of the pipe by carefully assuring the engagement of the pilot drill and shell cutter shaft.
- 14.9 Openings in the pipe barrel for tapping saddles installed on dry pipe shall be cut with a pilot drill and shell cutter. Torch cutting is not permitted.
- 14.10 Tapping operations must not commence before inspection by CWW' authorized representative.
- 14.11 A thick coat of bituminous material shall be applied to the straps and bolts of saddles after installation and cleaning or by enclosing polyethylene material in accordance **with Section 19 herein**. Coating or poly wrap will not be required if all metal surfaces are vinyl or epoxy coated and all bolts are stainless steel.

15. AIR/VACUUM RELIEF VALVES

- 15.1 Air/Vacuum relief valves shall be constructed with a stainless steel or nylon body, and have a working pressure rating of 150 psi minimum. All interior operating parts shall be constructed of stainless steel. Air/Vacuum relief valves shall have an integral type assembly which functions both as an air release and vacuum relief valve.
- 15.2 Air /Vacuum relief valves shall be installed at high points along the pipeline as shown on the Plans.
- 15.3 Air/Vacuum relief valves shall be installed in accordance with the typical detail below. The inlet connection of air/vacuum relief valves shall be 2-inches in diameter. Service or tap saddles and pipe fittings used in connecting the air relief valve shall be Stainless steel conforming to ANSI/AWWA Standard C226 or Brass conforming to AWWA Standard C800. Connections on the outlet side of air/vacuum relief valves shall be threaded and shall have Stainless Steel or Brass elbows installed as indicated below.

Cabot WaterWorks Standard Construction Specifications

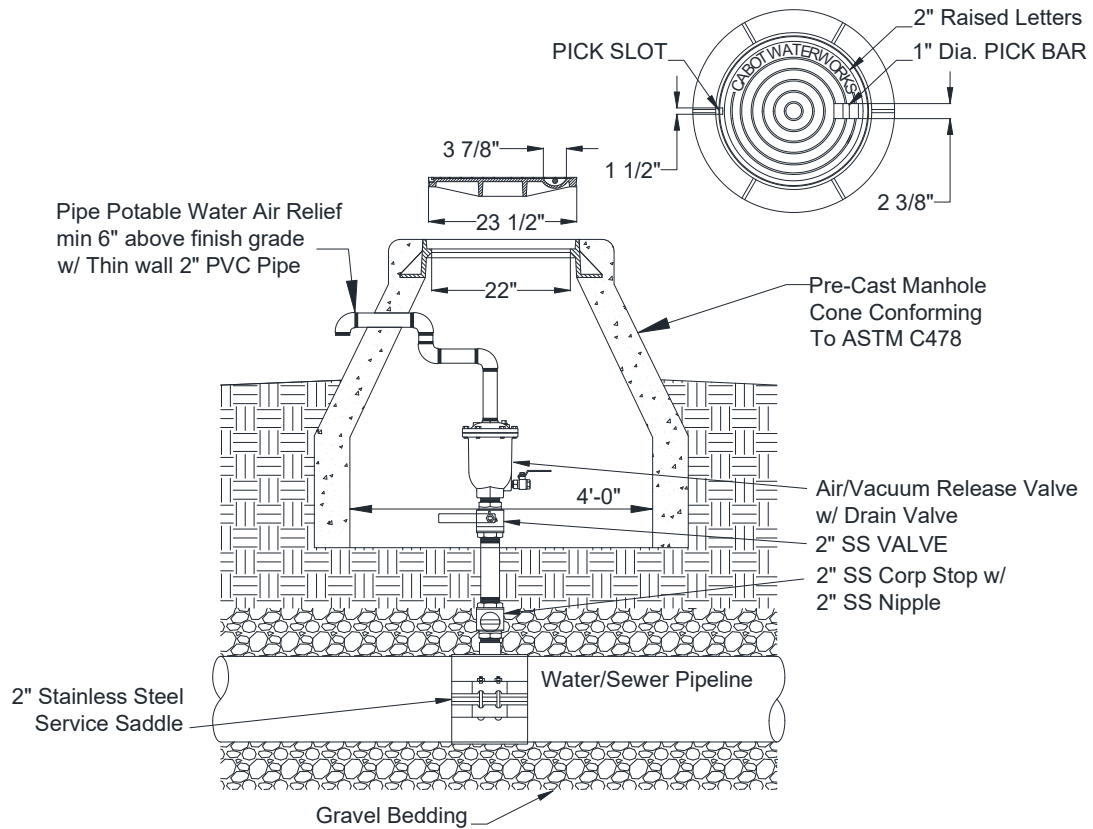

Typical Air/Vacuum Relief Valve

16. STEEL PIPE for CREEK CROSSINGS

- 16.1 Steel Pipe shall be used for Creek crossings as indicated on plans. Steel water pipe shall have minimum yield strength of 35,000-psi. The pipe shall conform to ASTM A-53 or ASTM A-135, Type E (electric resistance welded, Grade B) or Type S (seamless, Grade B). A letter of compliance from the Bidder or mill tickets shall be supplied to CWW for the delivered pipe.
- 16.2 Flanges for steel pipe creek crossings shall conform to AWWA Standard C207, class E, 275PSI.
- 16.3 Steel pipe shall not be used for direct burial installations. Ductile Iron pipe shall be used as a transition from direct burial to open creek crossings where steel pipe is to be used.
- 16.4 Maximum permissible spans for steel water pipe supported by AWWA C207, class E flanges are listed below. Steel water Pipe wall thickness shall be 3/8".

<u>Nominal Pipe</u> <u>Diameter (in.)</u>	<u>Wall Thickness</u> <u>(3/8")</u>
8"	45
10"	46
12"	47

17. FIRE HYDRANT INSTALLATION

- 17.1 Remove all dirt and foreign matter from the hydrant barrel and bottom section up to the main valve prior to installation. The main valve shall be in the "closed" position. The drain outlet shall be cleared of obstructions.
- 17.2 Hydrants shall be installed fully restrained with MJ swivel Tee or swivel MJ adapters or flange to flange connections. Hydrants shall have a resilient seated gate valve installed on the hydrant lead from the main. Tapping valves used for hydrant lead connections, qualify as an auxiliary valve.
- 17.3 Hydrants shall be located a safe distance from driveways, roadways and sidewalks and in a manner to provide complete accessibility, and shall stand plumb with the hydrant base at finished grade.

Cabot WaterWorks Standard Construction Specifications

- 17.4 Hydrants located on ARDOT right-of-way shall be placed at the right-of-way line.
- 17.5 Unless otherwise directed, the pumper nozzle shall face the street. The CONTRACTOR shall, if necessary, rotate the hydrant barrel or nozzle section at the flanged joint to obtain the desired nozzle position as directed by the ENGINEER.
- 17.6 The base of the hydrant shall be supported and well braced against firm undisturbed soil. Stone slabs, concrete blocks, or other suitable material may be used to block the hydrant. As directed by the ENGINEER, the hydrant shall have concrete blocking placed around the hydrant foot, taking care to not cover the drain port with concrete.
- 17.7 A drainage bed shall be provided under and around the base of the hydrant and extending at least six (6") inches above the drain outlet and shall conform to requirements for, Select Granular Bedding Material. Bedding shall be tamped around hydrant.
- 17.8 The hydrant drain outlet shall not be connected to a sewer.
- 17.9 New Hydrants shall be covered with plastic bags marked "Out-of -Service", until the hydrant is placed in-service.

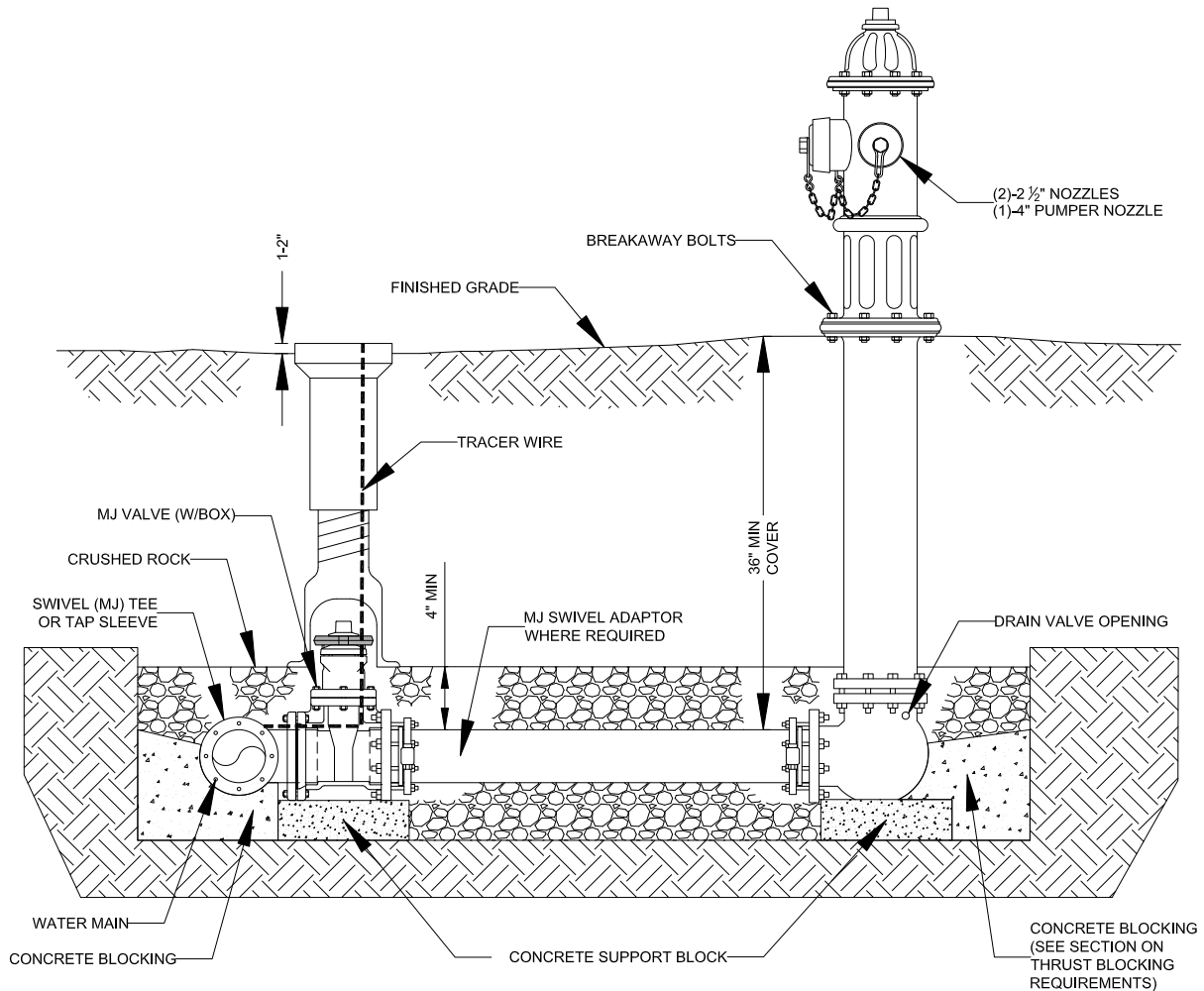

NOTE: CONCRETE BLOCKING SHALL NOT COVER HYDRANT DRAIN VALVE OPENING.

TYPICAL - FIRE HYDRANT ASSEMBLY

NTS

Cabot WaterWorks Standard Construction Specifications

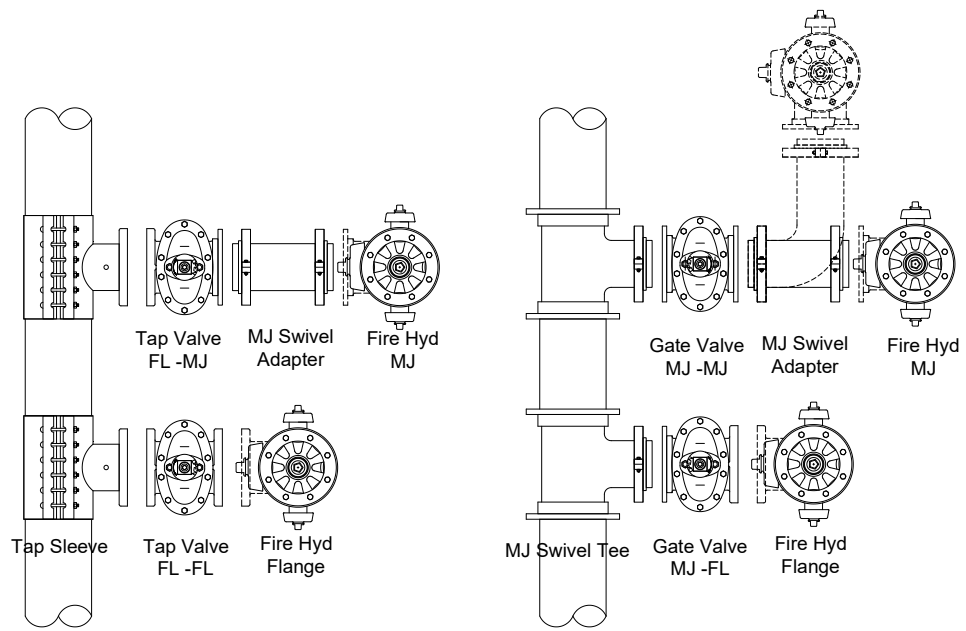

Typical Fire Hydrant Connection Detail

Cabot WaterWorks Standard Construction Specifications

- b). Polyethylene material, either in tubing form or in the form of flat sheet or rolls, as specified herein, shall be placed around all mechanical joints of pipe and fittings; all valves and fire hydrants with mechanical joint ends and all saddles, sleeves, and couplings, tapping saddles and any other appurtenances with exposed bolts.
- 19.2 Polyethylene Encasement shall conform to AWWA C105.
- 19.3 Polyethylene material shall conform to ASTM D4976, virgin polyethylene. Sheets or rolls shall be either;
- a). 8 mil, linear low density with 3,600 psi tensile strength or
 - b). 4 mil, high density, cross laminated with 6,300 psi tensile strength.
- 19.4 Polyethylene tubing shall be applied to pipe by one of the following methods:
- a). Method "A"/ Cut polyethylene tube to a length approximately two (2') feet longer than length of the pipe section. Slip the tube around the pipe centering it to provide a one (1') foot over lap on each adjacent pipe section, and bunching it accordion fashion lengthwise until it clears the pipe ends. Lower the pipe into the trench and make up the pipe joint with the preceding section of pipe. A shallow bell hole must be made at joints to facilitate installation of the polyethylene tube. After assembling the pipe joint, take bunched polyethylene from the preceding length of pipe, slip it over the end of the new length of pipe and secure in place. Then slip the end of the polyethylene from the new pipe section over the end of the first wrap until it overlaps the bell joint at the end of the preceding length of pipe. Secure the overlap in place. Take up the slack width to make snug, but not tight, fit along the barrel of the pipe, securing the fold at quarter points with tape. See Ductile Iron Pipe Research Association (DIPRA), "Polyethylene Encasement Installation Guide" at <http://www.DIPRA.org>.
 - b). Method "B"/ Cut polyethylene tube to a length approximately one (1') foot shorter than the length of the pipe section. Slip the tube around the pipe, centering it to provide six (6") inches of bare pipe at each end. Make polyethylene snug, but not tight; secure ends. Before making up a joint, slip a three (3') foot length of polyethylene tube over the end of the preceding pipe section, bunching it in accordion fashion lengthwise. After completing the joint, pull the three (3') foot length of polyethylene over the joint, overlapping the polyethylene previously installed on each adjacent section of pipe by at least one (1') foot; make snug and secure each end.
- 19.5 Odd-Shaped Appurtenances. Valves, tees, crosses and other odd-shaped pieces which cannot practically be wrapped in a tube, shall be wrapped with a flat sheet or split length of polyethylene tube. The sheet shall be passed under the appurtenance and brought up around the body. Seams shall be made by bringing the edges together, folding over twice, and taping down. Slack width and overlaps at joints shall be handled as described in paragraph 19.4 above. Tape polyethylene securely in place at valve stem and other penetrations.
- 19.6 Openings in Tubing Material. Openings for branches, service taps, blow-offs, air valves, and similar appurtenances shall be made by making an x-shaped cut in the polyethylene and temporarily folding the film back. After the appurtenance is installed, tape the slack securely to the appurtenance and repair the cut, as well as any other damaged areas in the polyethylene with tape.
- 19.7 Junctions between Wrapped and Unwrapped Pipe. Where polyethylene wrapped pipe joins a pipe which is not wrapped, extend the polyethylene tube to cover the unwrapped pipe a distance of at least two (2') feet and secure the end.
- 19.8 The polyethylene material shall be secured around the pipe and appurtenances by at least three (3) circumferential wraps of tape (Section 9, Material Specifications).
- 19.9 All tongs, cables or chains that are used for lifting pipe and appurtenances that have been encased in polyethylene material shall be adequately padded to prevent damage to the material.
- 19.10 Repair any rips, punctures, or other damage to the polyethylene with tape or with a short length of polyethylene tube cut open wrapped around the pipe and secured in place.
- 19.11 Polyethylene material shall be stored on the job site in such a manner that it is not exposed to direct sunlight. Exposure during installation shall not exceed forty-eight (48) hours.
- 19.12 Backfill material shall be the same as specified for pipe without polyethylene wrapping. Special care shall be taken to prevent damage to the polyethylene wrapping when placing backfill. Backfill material shall be free from cinders, refuse, boulders, rocks, stones and/or other material that could damage polyethylene.

Cabot WaterWorks Standard Construction Specifications

20. ENCASEMENT STRUCTURES (Open Cut or Directional Boring)

- 20.1 Encasement pipe is required for all water and wastewater lines (including services) crossing Arkansas State Highways, Major, Minor, and Collector; City and County Roads and shall conform to the following requirements:
- Encasements shall be designed to support the load of the roads and superimposed loads thereon and, as a minimum, shall equal the structural requirements for highway drainage facilities. Encasements shall be composed of materials of satisfactory durability under conditions to which they may be subjected.
 - Encasements shall have a minimum cover of forty-eight (48) inches measured vertically from the flow line of parallel ditches or sixty (60) inches measured vertically from the highway surface; whichever provides the greater cover.
 - Encasement pipe shall extend the width of road right of way lines, when practical, and may be required by the ARDOT. As a minimum, encasements shall extend six (6) feet beyond the toe of the slope in any embankment section, the flow line of any parallel ditches, or back of any curb as applicable for the highway section.
 - Encasement shall be provided under medians and the area between frontage roads and the main lanes.
 - Encased crossings of partially controlled or fully controlled access highways shall be encased the full width of the control of access.
 - All crossings involving frontage roads shall be encased between the control of access and frontage road and the pipe shall extend a minimum of six (6) feet beyond the toe of the slope in any embankment section, the flow line of any parallel ditch, or the back of any curb as applicable on the side of the frontage road opposite the main lanes.
- 20.2 The CONTRACTOR shall inspect the location where encasement structures are to be installed and become familiar with the conditions under which the work will be performed and with all necessary details as to the orderly prosecution of the work. The omission of any details in the Plans and Specifications for the satisfactory installation of the work in its entirety, which may not appear herein, shall not relieve the CONTRACTOR of full responsibility.
- 20.3 The CONTRACTOR shall satisfy himself of soil conditions by means he deems necessary; i.e., exploratory boring or exploratory pit excavations at tunnel ends. All such exploratory work shall be done in such a manner as to not jeopardize highway or railroad fill, and shall be satisfactorily back filled and the site restored.
- 20.4 **Submittals:** Contractor is required to submit their proposed steering (e.g. articulated steering head, offset jets incorporated into a direction sensing and steering head, etc.) and tracking equipment (e.g. transmitter & receiver, electromagnetic down-hole navigational system, water level line, laser & survey tools, etc.), procedures, and proposed locations requiring surface or subsurface access.
- 20.5 The size structure as shown on the Plans is considered as the "minimum acceptable size". If the CONTRACTOR deems that it would be to his advantage to install a larger structure, he may do so subject to the approval of the ENGINEER. If the CONTRACTOR elects to use large structures, the unit bid price as stated in the Bid for the size structure specified will be considered the unit bid price for the larger structure. In no case will CWW be liable for extra payment for structures larger than the size specified.
- 20.6 Steel casing pipe shall have minimum yield strength of 35,000-psi and a wall thickness indicated in the Casing Pipe Sizing Table below. The pipe shall conform to ASTM A-53 or ASTM A-135, Type E (electric resistance welded, Grade B) or Type S (seamless, Grade B). A letter of compliance from the Bidder or mill tickets shall be supplied to CWW for the delivered pipe.
- 20.7 PVC and HDPE casing pipe, where approved by the Engineer, and shall conform to the PVC DR 25 or HDPE pipe shall be SDR-9.
- 20.8 Encasement pipe shall be installed at the grades and alignment shown on the Plans. Variations shall be approved by the ENGINEER.
- 20.9 Where open cut is not practical or permitted, the encasement structure shall be installed by Directional Boring with the following requirements:
- All bores shall be encased with smooth wall steel encasement pipe and shall be connected by full penetration butt welding continuously around the circumference of the casing. Welded joints of encasement pipe shall be aligned with no offsets or bends from joint to joint. Steel Encasement pipe shall meet the minimum diameter and wall thickness indicated in the table below.

Cabot WaterWorks Standard Construction Specifications

- b). **All joints of encasement pipe shall be watertight.** The inside surface of encasement pipe shall be free from welding material and other obstructions that restrict sliding carrier pipe into the casing.
 - 20.9.1.b.1. Cabot Waterworks inspects the interior casing by remote video camera CCTV.
 - 20.9.1.b.2. Installed Encasement Pipe shall pass a low pressure air test in accordance with procedures specified for low pressure testing for sewer pipelines, later in these specifications.
 - c). An auger pilot hole shall first be attempted to determine if rock will prevent the installation of the casing. If the pilot hole is successfully made, the casing shall be installed.
 - d). Bore machine shall be set to attain the specified grade, slope and alignment of the casing. bores shall be conducted in a manner consistent with industry accepted practices that minimize annular voids and over-breaks and protect the integrity of ground cover, surfaces and structures. In no case, shall overbore exceed 5 percent of the pipe diameter.
 - e). Water pressure to jet a hole ahead of the auger shall not exceed 10 pounds per square inch (psi). Over-reamed bore holes are not permitted. Any annular space between the casing and bore hole shall be filled by pressure grouting.
 - f). The leading section of casing shall be equipped with a bore head securely anchored thereto to prevent any wobble or variation in alignment.
 - g). Excavation shall be performed entirely within the cutter head and no excavation in advance of the casing pipe shall be permitted.
 - h). Excavated material shall be removed from the casing as excavation progresses, and no accumulation of such material within the casing will be permitted.
 - i). The boring operations shall be done simultaneously with correct line and grade carefully maintained for the casing. Holes for casing shall be bored with an auger mounted to casing pipe with the auger extending a short distance beyond the lead end of the pipe to preclude caving.
- 20.10 Pits and trenches shall be protected in accordance with Occupational Safety and Health Administration's (OSHA) Excavation and Trenching Safety standard, Title 29 of the Code of Federal Regulations (CFR), Part 1926.650.
- 20.11 Excavation for bore pits shall not intrude into the flow line of parallel ditches or the slope of embankment sections.
- 20.12 The excavation, bedding and backfill for Open Cut installation of encasement pipe shall be in accordance with these specifications for PIPE BEDDING & BACKFILL.
- 20.13 Carrier pipe installed in casing shall have casing spacers installed at intervals indicated in the table below, with the exception for welded PE or HDPE carrier pipe may not require casing spacers upon approval of CWW. Casing spacers shall be constructed of a Stainless Steel or Polyethylene with runners designed to support the weight of the filled pipe. Acceptable manufacturers of casing spacers are Advance Products and Systems, Inc., of Lafayette, Louisiana. If, after installation of the pipe, adequate stability has not been provided, in the opinion of the ENGINEER, the pipe shall be removed or the annular spaces between the pipe and encasement structure be filled with grout or sand, as required by the ENGINEER. Carrier pipe shall not be bear on bell joints in casing.
- 20.14 Carrier Pipe that is pressurized (Water or Sewer) will require bell joint restraint when elbow fittings are used immediately outside of casing. Bell Joint restraints shall be RIEBERLOC, FIELDLOC or equal.
- 20.15 Carrier pipe shall be installed in a manner to assure that the joints are not over deflected or pulled apart during the process. The pipe shall be jointed and pulled or jacked through the encasement structure with a cable capable of pulling the total number of pipe lengths and shall be threaded through the casing. The pipe shall be pulled into the casing one joint at a time by means of a slow steady pull on the cable and guided by hand to prevent damage to the pipe, and to prevent the pipe and casing spacers from rotating out of alignment. The cable shall be attached to a wood block (of sufficient size to take the strain) placed across the end of the pipe. After each joint of pipe is pulled into the casing, the cable shall be taken loose and threaded through the next joint of pipe to be added to the line. This process shall be repeated until the pipeline section is completely installed in the casing.

Cabot WaterWorks Standard Construction Specifications

- 20.16 Ends of Encasement shall be sealed using a non-shrink grout or neoprene molded rubber end seal with stainless steel banding around casing and carrier pipe. Casing End seals shall be manufactured by Advance Products & Systems Model AC or Model AM or equal. End seals shall be approved by the Engineer.

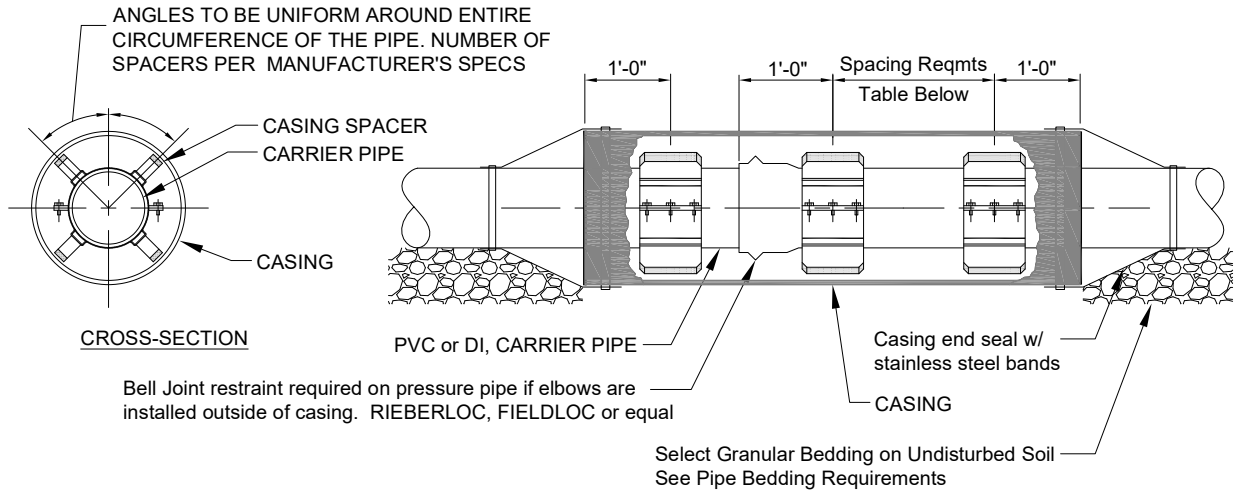

Casing Pipe sizing table

Nominal Pipe Diameter (in.)	Casing Size Inside Dia. (in.)	Steel Casing Wall Thickness (in.)	Casing Spacer Maximum Spacing (ft.)
4"	8 - 10"	0.25"	6.7' & each side of bell joint
6"	10 - 12"	0.25"	8.3' & each side of bell joint
8"	12 - 16"	0.3125"	10.0' & each side of bell joint
10"	16 - 18"	0.3125"	10.0' & each side of bell joint
12"	18 - 20"	0.375"	10.0' & each side of bell joint
14 - 15"	24 - 26"	0.4375"	10.0' & each side of bell joint
16"	28 - 30"	0.4375"	10.0' & each side of bell joint
18"	30 - 32"	0.5"	10.0' & each side of bell joint
20 - 21"	32 - 34"	0.5"	10.0' & each side of bell joint
24"	36 - 38"	0.625"	10.0' & each side of bell joint

21. CONCRETE THRUST BLOCKS & ANCHOR COLLARS FOR PIPE FITTINGS

- 21.1 Concrete thrust blocks and anchors shall be provided along the pipeline in accordance with the **Typical Thrust Blocking Details** below, or as directed by the ENGINEER.
- 21.2 Concrete shall conform to requirements of Section 22, "Concrete Mix – Placement & Finishing" of these specifications. Cold weather requirements for concrete in paragraph 22.25 shall apply for thrust blocking.
- 21.3 **Dry** "Quick Crete" concrete will not be allowed for concrete blocking. "Quick Crete" concrete may be used for blocking if mixed with water per manufacturers recommendations.
- 21.4 Concrete for thrust blocks shall be placed against undisturbed soil. The excavation shall be hand shaped and free of loose material. Forms shall be used to confine the concrete in areas other than that part that is in contact with undisturbed soil in the direction of the thrust.
- 21.5 Concrete shall not be placed where it interferes with the removal of any joint accessories such as bolts, followers, threads, collars, couplings, etc. Fire hydrant drains shall not be restricted.
- 21.6 The top of the concrete thrust block or anchor collar shall be struck off with a wood straight edge or float.
- 21.7 All placement of concrete must be in the presence of the ENGINEER or his representative. The CONTRACTOR is cautioned that he may be required to remove, without compensation, any concrete placed in the absence of the ENGINEER or his representative.
- 21.8 Backfill over concrete thrust blocks or anchor collars shall not be placed before the concrete has attained initial set.

Cabot WaterWorks Standard Construction Specifications

- 21.9 No thrust blocks shall be less than six (6") inches thick between the pipeline or appurtenances and undisturbed soil in the direction of thrust
- 21.10 The excavation shall be free of water before concrete is placed. Steel reinforcement, as specified on the plans, shall be placed in accordance with paragraph 22.19 herein.
- 21.11 The pipe or appurtenances shall be cleaned before placing concrete when the concrete is to be in direct contact with the pipe or appurtenance.
- 21.12 The area of contact of the thrust blocks and anchor collars shall be sufficient to resist the thrust. This will vary depending on the safe bearing value of the soil. Suggested safe soil bearing values are as follows:

<u>TYPE OF SOIL</u>	<u>Estimated Bearing Capacity</u> <u>(lbs./sq.ft.)</u>
Muck, Peat, etc.	0
Soft clay	500
Sand	1000
Sand and Gravel	1500
Sand and Gravel with Clay	2000
Sand and Gravel cemented with Clay	4000
Hard pan	5000

- 21.13 The above values are approximate and will vary considerably and are intended to be used only as a guide. The **CONTRACTOR** is responsible for determining the soil bearing value or taking other action to assure that the bearing area is adequate to restrain the pipe or appurtenances.
- 21.14 Where the soil is unstable or in the case of recent fill areas, the following procedures shall apply either singly or in a combination:
- a). Thrust blocks shall be of adequate size to restrain pipe or appurtenances by mass alone without depending on horizontal bearing of the soil.
 - b). The excavation shall extend deep enough to contact firm soil and the block brought up to the pipe or appurtenances and constructed so that the block acts as a beam and will provide restraint required. Such block shall be reinforced with steel reinforcing bars.
 - c). Anchor blocks shall be constructed in a firm soil and tie rods extended to the pipe or appurtenances.
- 21.15 Thrust blocks for vertical bends shall be adequate to resist the thrust by mass alone when the thrust is upward.
- 21.16 Thrust blocks and anchor collars shall be adequate to restrain the pipe appurtenances at the specified test pressure. The following table lists the resultant thrust at certain fittings at a pressure of 100 psi In order to determine the thrust at the test pressure these values are to be multiplied by a factor equal to the test pressure divided by 100.

<u>Thrust per 100 psi Pressure</u>					
<u>Fitting Thrust (lbs. of force)</u>	<u>4"</u>	<u>6"</u>	<u>8"</u>	<u>10"</u>	<u>12"</u>
22 1/2° Bend	600	1,200	2,000	3,300	4,400
45 °	1,100	2,300	4,100	6,300	9,100
90 °	1,800	4,000	7,200	11,200	16,000
Plug, Valves, Tees, Dead Ends	1,300	2,900	5,100	7,900	11,300

- 21.17 The projected soil bearing area required to resist the thrust developed in pipe bends and fittings shall be determined by dividing the pounds of thrust for the fitting size, from the table above, by the soil bearing capacity. The result of this computation will be square feet of projected area perpendicular to the direction of thrust as indicated in the figures below.

Cabot WaterWorks Standard Construction Specifications

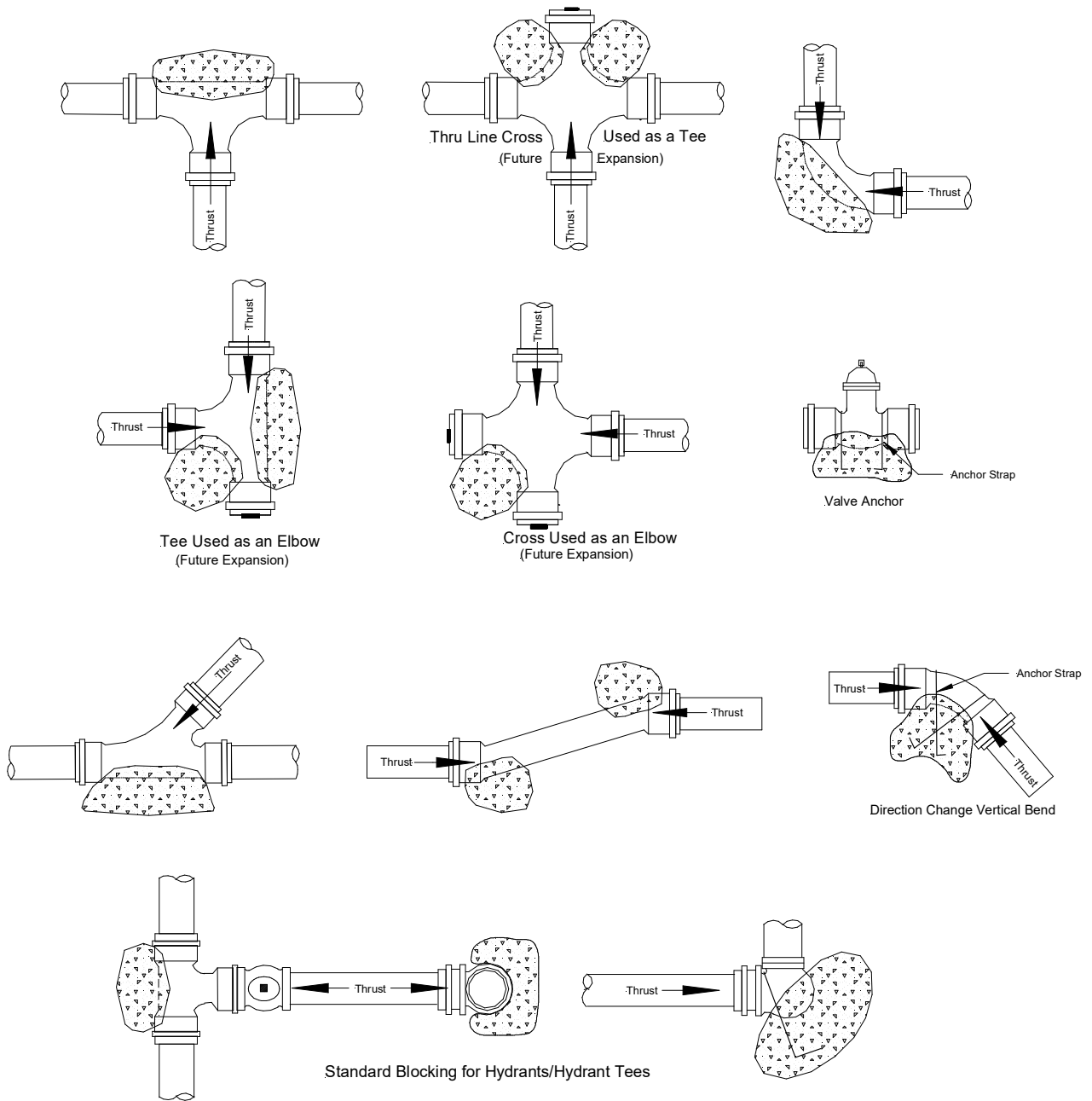

Typical Thrust Blocking Details

21.18 Concrete thrust blocks or anchor collars that fail to restrain the pipe or appurtenances shall be replaced by the CONTRACTOR at his expense.

22. CONCRETE MIX - PLACEMENT & FINISHING CONCRETE

22.1 Concrete materials shall conform to the following standards:

- a). ASTM C94 – “Standard Specification for Ready Mix Concrete”
- b). ASTM C150 – “Standard Specification for Portland Cement”, Type I

Cabot WaterWorks Standard Construction Specifications

- c). ASTM C33 – “Standard Specification for Concrete Aggregates”
- d). ASTM C387 – “Standard Specification for Packaged, Dry, Combined Materials for Mortar and Concrete”
- 22.2 Class "A" concrete shall have a 28-day compressive strength of at least 4,000 psi. Class "A" Concrete shall be used for sidewalks, street surfaces, curb & gutters, ditch paving, driveways, structures such as vaults, manholes, protective slabs over pipelines and other facilities, footing pipe supports and anchor collars.
- 22.3 Class "B" concrete may be used for thrust blocking and shall have a 28-day compressive strength of at least 2,500 psi.
- 22.4 Only potable water shall be used for concrete mix.
- 22.5 Fine aggregate shall consist of clean, sound, sand conforming to ASTM Standard C33 meeting the following grading requirements:

GRADATION FOR FINE AGGREGATE - ASTM C 33		
<i>Sieve Designation (square openings)</i>		<i>Percentage by Weight Passing Sieves</i>
<i>in.</i>	<i>mm.</i>	
3/8 in.	9.5 mm	100
No. 4	4.75 mm	95–100
No. 8	2.36 mm	80–100
No. 16	1.18 mm	50–85
No. 30	600 micro-m	25–60
No. 50	300 micro-m	10–30
No. 100	150 micro-m	2–10

- 22.6 Coarse aggregate shall consist of crushed stone, gravel, or other inert material of similar characteristics, having clean, hard, strong, durable non-coated particles meeting the following grading requirements:

Gradation for COARSE Aggregate - ASTM C 33		
<i>Sieve Designation (square openings)</i>		<i>Percentage by Weight Passing Sieves</i>
<i>in.</i>		<i>%</i>
1		100
3/4		90–100
1/2		20–55
3/8		0-15
No. 4		0-5

- 22.7 In no case shall the maximum aggregate size exceed one-third (1/3) of the design thickness of any part of a structure.
- 22.8 Limits for deleterious substances in Fine and Course aggregates.

<u>Deleterious Material</u>	<u>Maximum percent by weight</u>
Clay Lumps, Friable particles & Chert	1.0 %
Material finer than # 200 sieve	1.0 %
Coal and Lignite	0.5 %

- 22.9 Aggregates for use in concrete shall not contain any materials that are deleteriously reactive with the alkalis in the cement. Aggregates shall be tested for potential alkali reactivity in accordance with ASTM Standard C289 and C227, test results shall be negative.

Cabot WaterWorks Standard Construction Specifications

22.10 Concrete Proportions and Consistency.

- a). Slump of concrete shall be between 2 inches and 4 inches as tested in accordance with ASTM C143.
- b). Air Content: $6\% \pm 1.5\%$ as tested in accordance with ASTM C231 for air-entrained concrete.
- c). Water-Cement Ratios shall be limited to 0.42 for all concrete unless otherwise specified.

22.11 Mixing and Hauling Concrete. Concrete shall be mixed in a batch mixer of a type designed to insure uniform and thorough distribution of the materials throughout the mix. Its size shall be such as to produce a volume of concrete consistent with demands of each pour. It shall be equipped with a water metering device for accurate measurement of water. Charges of cement shall be by full sacks of cement; the use of fractional sacks, or reclaimed cement, will not be acceptable. All concrete shall be mixed for a period of not less than five (5) minutes after all materials, including the mixing water, have been placed in the drum. The entire contents of each batch shall be discharged from the drum before any material for the succeeding batch is placed therein. When the mixing operation for each period is completed, the mixer drum shall be cleaned thoroughly. Concrete shall be deposited within forty-five (45) minutes after it is mixed.

22.12 If the CONTRACTOR elects to use a central mixing plant, he shall provide sufficient hauling equipment, properly designed to prevent segregation and loss of mortar, and to permit discharge without segregation. When the hauling and placing operation for each period is completed, the hauling equipment shall be cleaned thoroughly.

22.13 The CONTRACTOR shall obtain from the supplier of ready-mixed concrete, the supplier's agreement to inspection by the ENGINEER, to the full extent deemed necessary by the ENGINEER.

22.14 TESTING CONCRETE: At the direction of the ENGINEER, the Contractor shall collect samples of concrete for testing as specified below.

- a). Contractor shall collect concrete compression test specimen in accordance with ASTM Standard C31.
- b). Contractor shall have concrete specimens tested for compressive strength in accordance with ASTM Standard C39.

22.15 All reinforcing bars shall be "Billet-Steel Concrete Reinforcement Bars" conforming to ASTM Designation A15 or "Rail-Steel Concrete Reinforcement Bars" conforming to ASTM Designation A16. Billet-Steel bars shall be intermediate grade with minimum yield point of 40,000 psi

22.16 All reinforcing bars shall be deformed bars. Deformation shall comply with "Minimum Requirements of the Deformation of Deformed Steel Bars for Concrete Reinforcement - ASTM Designation A305."

22.17 When the volume of concrete required at the work site is less than one-third (1) cubic yard, mixing may be accomplished by hand tool methods. The concrete shall be mixed in a clean, water-tight vessel to the extent necessary to assure that the cement, aggregate and water are thoroughly integrated. The concrete mix shall be QUIKRETE Concrete Mix #1101 conforming to ASTM C387 – "Standard Specification for Packaged, Dry, Combined Materials for Mortar and Concrete" with a Only that amount of water required to provide a stiff, workable mix shall be used. Hand mixed concrete shall obtain the strength requirements specified above for Class "A" and "B" concrete.

22.18 PLACEMENT & FINISHING CLASS "A" CONCRETE

- a). Forms shall be constructed before placement of any concrete unless otherwise authorized by the ENGINEER.
- b). Forms shall conform to shapes, lines, and dimensions of the members as specified on the Plans, or as required to conform to the original shape and dimensions in the case of replacement structures, and shall be sufficiently tight to prevent leakage of mortar. They shall be properly braced or tied together so as to maintain position and shape. They may be constructed of any material with sufficient strength which will provide the finished work a satisfactory surface; however, metal forms will not be permitted for concrete which will be exposed on any of the completed work, except upon the specific approval of the ENGINEER.
- c). In those cases in which paved surfaces are being replaced such as sidewalks, driveways, curb, gutter, etc., the edge of adjacent existing surfaces must be cut straight and smooth using a concrete saw or other suitable tool. The forms shall be constructed in such manner that a smooth concrete surface is produced which matches the existing surfaces on each side.

Cabot WaterWorks Standard Construction Specifications

- d). Forms shall be removed in such a manner as to insure the complete safety of the structure. When the structure is supported on shores, the removable floor forms, beams and girder sides, and column and similar vertical forms may be removed after 96 hours, providing the concrete will not be injured. In no case shall supporting forms or shoring be removed until members have acquired sufficient strength to support their weight and imposed loads safely.
- e). Forms shall be coated with oil before placement of reinforcing steel or concrete. Excessive coating material shall not be allowed to form or stand in puddles in the forms nor allowed to come in contact with concrete against which fresh concrete will be placed.

22.19 Placement of Reinforcement.

- a). At the time concrete is placed, metal reinforcement shall be free from rust scale or other coatings that will destroy or reduce the bond. All bars shall be shop bent, unless otherwise permitted by the ENGINEER. No bars partially embedded in concrete shall be field bent except as shown on Plans or as specifically permitted by the ENGINEER. Field bonding of rail steel bars will not be permitted.
- b). Metal reinforcement shall be accurately placed according to the Plans or as specified herein and adequately secured in position by concrete, metal, or other approved chairs, spacers or ties.
- c). No splices of reinforcement shall be made except as shown on the Plans, or as specified, or as authorized by the ENGINEER. All welding shall conform to the American Welding Society's Recommended Practices for Welding Reinforcing Steel, Metal Inserts and Connections in Reinforced Concrete Construction (AWS D12.1), unless otherwise authorized by the ENGINEER. All laps and splices shall be in accordance with ACI 318, using $f_c = 3000$ psi and $f_y = 60,000$ psi unless otherwise shown on the Plans.
- d). The reinforcement shall be protected by the thickness of concrete indicated in the Plans. Where not otherwise shown, the thickness of concrete over the reinforcement shall be as follows:
- e). Where concrete is deposited against the ground without the use of forms, not less than 3-inches, except wire mesh reinforcement for concrete slabs which may be within 1 ½ inches of the ground.
- f). Where concrete is to be exposed to the weather or to the ground but placed in forms, not less than 2-inches for bars larger than No. 5 and 1 ½ inches for No. 5 bars or smaller.
- g). In slabs and walls not exposed to the ground or to the weather - not less than ¾ -inch.
- h). In all cases - at least equal to the diameter of the bars.
- i). Reinforcement for Curb and Gutter. Reinforcement shall consist of #3 bars spaced at 6 inch centers longitudinally with #4 transverse tie bars spaced at 2-foot centers. The bars shall be firmly held in place by wiring bars together. Bar chairs or other suitable steel devices shall be used to support the bars at a level 3-inches above the bottom of the concrete.
- j). Reinforcement for Sidewalk, Ditch Paving, Slope Protection and Driveway Surfaces. Reinforcement shall consist of 6-inch x 6-inch mesh, #6 for driveways and #9 for ditch paving, slope protection and sidewalks.

22.20 Joints and Joint Filler

- a). Water stops shall be installed at no additional cost to CWW for construction joints in walls and slabs below finished ground elevation, and in all water bearing structures. Where a joint is to be made, the surface of the concrete shall be thoroughly cleaned and all laitance removed. In addition, vertical joints shall be thoroughly wetted and flushed with a coat of neat cement grout immediately before placement of new concrete.
- b). Expansion and contraction joints are required every 12 feet for replacement sidewalk, driveway, curb and gutter, ditch paving or other slabs.
- c). Use a molded joint filler that is ¾" to 1 inch thick, conforming to ASTM Designation M33, and shall be of sufficient dimension to extend through the full depth of the paved surface.
- d). Embedded items, wall fittings and anchor bolts shall be installed as shown on the Plans. Embedded items shall be worked-out in advance of the concrete pour, giving the ENGINEER ample time for inspection of all items to be embedded.

Cabot WaterWorks Standard Construction Specifications

22.21 Placing Concrete.

- a). **All placement of concrete must be in the presence of the ENGINEER or his representative. The CONTRACTOR is cautioned that he may be required to remove, without compensation, any concrete placed in the absence of the ENGINEER or his representative.**
- b). Equipment for chuting, pumping and pneumatically conveying concrete shall be of such size and design as to ensure a practically continuous flow of concrete at the delivery end without separation of materials. All concrete in walls and columns shall be poured through tremies unless otherwise permitted by the ENGINEER. The free fall of concrete shall be held to a minimum.
- c). Concrete shall be deposited as nearly as practicable in its final position to avoid segregation due to re-handling or flowing. The placing of concrete shall be carried on at such a rate that concrete is at all times plastic and flows readily into the spaces between the bars. Concrete that has been contaminated by foreign material shall not be used, nor shall re-tempered concrete be used.
- d). When placing concrete is started, it shall be carried on as a continuous operation until placement of the panel or section is complete.
- e). In placing concrete, care shall be taken that the freshly placed mass is so placed and vibrated that there is no tendency for the coarse aggregate to segregate from the mortar, that no rock pockets are left, that the concrete flows readily around the steel and into the extremities of the forms, and the whole freshly-placed mass becomes a plastic jelly-like mass but without free water in appreciable quantity on its surface. Class "A" concrete shall be poured with mechanical or magnetic internal vibrators.
- f). Water shall be removed from place of deposit before concrete is placed unless otherwise permitted by the ENGINEER. Before depositing concrete on or against concrete which has taken its initial set, the surface of the hardened concrete shall be broken off down to coarse aggregate and wire brushed to remove foreign matter and laitance. A layer of grout of the same cement-sand ratio as the concrete without coarse aggregate shall be placed to a thickness of one (1) to two (2) inches on the brushed surface after which the new concrete shall be placed immediately.
- g). Concrete placed directly on the ground shall be placed in the forms on a compacted wetted sub-grade and shall be tamped and spaded until mortar covers the entire surface. Tamping and spading shall be given special attention in order to prevent voids in the concrete.
- h). Curb and Gutter Section. The cross section of the curb and gutter shall conform to that of adjacent sections or as directed by the ENGINEER. The surface shall be struck off smooth between templates, shaped to the required cross section, and it shall be finished with a wooden float and steel trowel and a broom to produce a uniform finish to match that of adjacent sections. The curb and gutter shall be grooved with an approved grooving tool at intervals equal to those of adjacent sections where applicable.
- i). After the concrete has been deposited, it shall be approximately leveled and struck off to such depth below the finish grade as required to place reinforcing mats or wire mesh, and shall be properly consolidated prior to placing the reinforcing mats or mesh, when applicable. Additional concrete shall be deposited and struck off to a depth above the finish grade that when properly consolidated, the surface shall conform to the line and grade required to match adjacent surfaces. The strike-off board shall be straight, free from warp, and shod on the striking surface with a steel strip. The strike-off board shall be moved forward with a combined longitudinal and transverse motion and without raising either end above the side forms during the strike-off process. A slight excess of material must be kept in front of the cutting edge at all times.
- j). Immediately following screeding and compaction operations, the slab surface shall be tested for trueness with a straight-edge. Use a wood float, darby, or bullfloat to eliminate high and low spots and to embed large aggregate. This shall be done in a manner to produce even, uniform surfaces so that surface irregularities do not exceed 1/8 inch in 10 feet. The straight-edge testing and floating operation shall continue until the entire surface is found to be free from observable departures from the straight edge, and until the surface of the slab has the required grade and contour.

Cabot WaterWorks Standard Construction Specifications

22.22 Concrete Finishing.

- a). The concrete shall be worked with suitable tools until a finish which matches that of adjacent surfaces is achieved.
- b). Exposed aggregate finish. Scrubbed finish shall be produced on green concrete. The surface shall be thoroughly wetted and scrubbed with stiff fiber or wire brushed, using water freely, until the surface film of mortar is removed and the aggregate is uniformly exposed. The surface shall then be rinsed with clean water. If portions of the surface have become too hard to scrub in equal relief, dilute hydrochloric acid (commercial muriatic acid diluted with 4 to 10 parts water) shall be used after the concrete is at least two (2) weeks old to facilitate the scrubbing. The acid shall be removed within fifteen (15) minutes from the finished surface with clean water. This operation may be facilitated by casting the concrete against form faces which have been coated with a chemical retarder to keep the mortar adjacent to the form from setting. Every effort must be exerted to assure that the new surface matches any existing adjacent surfaces.
- c). All exposed inner and outer (above grade) walls of structures shall be finished as follows: Forms shall be removed from such surface as soon as structurally possible and when approved by the ENGINEER. All imperfections and depressions shall then be immediately filled with mortar. The concrete surfaces shall then be machine or hand rubbed until the entire surface has a smooth, homogenous, pleasant-appearing finish of uniform texture and color. Any delay in patching or rubbing such surfaces shall be cause for rejection of the entire structure. No mortar or wet cement shall be used in finishing except the mortar necessary to fill imperfections. Edging tools shall be used on all exposed joints and edges. All exposed corners shall be chamfered as shown on the Plans.
- d). All other wall surfaces of structures shall be finished as follows: Forms shall be removed from such surfaces as specified above. All imperfections and depressions shall then be immediately filled with mortar and rubbed with a wooden float or steel trowel to give a uniform appearance. Spurs shall be removed from the concrete surface. No over-all machine or hand rubbing is required.
- e). Floors of structures and ditch pavement shall be trowel finished.

22.23 Concrete shall be protected from damage while curing. Provisions shall be made for maintaining concrete in moist condition for a period of at least ten (10) days after placement.

22.24 After removal of forms and finishing, as specified elsewhere herein, backfill shall be placed around the structure and thoroughly compacted.

22.25 Cold-Weather Requirements.

- a). Concrete shall not be placed when the ambient temperature is below 40°F, or when the concrete is likely to be subjected to freezing temperatures before final set has occurred. Concrete footings or slabs shall not be placed over frozen ground. The temperatures of the concrete when placed shall not be less than 45°F. Heated materials shall be free of ice, snow and frozen lumps before entering the mixer. Methods and equipment for the heating of materials shall be subject to the ENGINEER'S approval. Suitable means shall be provided for maintaining the concrete at a temperature of at least 45°F for not less than 96 hours after placing.
- b). Special methods shall be used to protect concrete slabs in from freezing after concrete placement. Methods shall include covering of slabs with hay or other insulating material, protection of insulation from wetting with tarpaulins, introduction of heat, construction of enclosures, or other methods, depending upon the severity of the weather. The housing, covering or other protection used in connection with curing shall remain in place and intact at least 24 hours after the artificial heating is discontinued. Methods to be used shall be proposed in advance of the work and shall be approved by the ENGINEER. Salt, calcium, chloride, or other chemicals shall not be mixed with the concrete to prevent freezing.
- c). Any concrete damaged by freezing shall be removed to the satisfaction of the ENGINEER, and replaced, all at the expense of the CONTRACTOR.

22.26 Hot Weather Requirements.

- a). In hot weather, suitable precautions shall be taken to avoid drying of the concrete prior to finishing operations. Use of windbreaks, sunshades, fog sprays, or other devices shall be provided as directed by the ENGINEER.

Cabot WaterWorks Standard Construction Specifications

- b). Concrete deposited in hot weather shall not have a placing temperature that will cause difficulty from loss of slump, flash set, or cold joints. Concrete temperatures shall be less than 90°F unless higher temperatures are permitted by the ENGINEER.
- c). The use of curing compounds or other additives shall be prohibited unless approval of its use has been secured, in advance, from the ENGINEER.

23. **REPLACEMENT of PAVED SURFACES**

- 23.1 Paved Surfaces shall mean Portland cement concrete and/or bituminous asphalt pavement
- 23.2 The CONTRACTOR shall replace or repair all paved surfaces removed or disturbed during the progress of work.
- 23.3 All replacement or repairs of paved surfaces within the right-of-way of public streets or roads must conform to requirements of, and be approved by, the state, county or local authority having jurisdiction. Concrete surfaces, except street pavement, shall be constructed in accordance with **Section 22**, unless otherwise directed by state, county or local authorities having jurisdiction. Street repairs shall conform to the detail for Type 5 Bedding; see **Section: Pipe Bedding and Backfill**.
- 23.4 The materials used shall be of the same type as that removed or materials approved by the ENGINEER or state, county, or local authority having jurisdiction.
- 23.5 The following shall be considered minimum requirements with respect to replacing asphaltic concrete pavement other than Public Street or alley pavement.
 - a). The pavement thickness shall be at least as thick as adjacent pavement but in no case shall it be less than two (2") inches thick.
 - b). Before placement of new surface material, all excess material (temporary cold mix asphaltic concrete, crushed stone, soil, etc.) shall be removed to a depth at least equal to the specified thickness of the replacement surface. The base surface on which the replacement material is to be placed shall be finished smooth and any wet material and debris removed.
 - c). Preparation and Priming. No bituminous material shall be placed upon a surface having excess moisture or when general weather conditions are not suitable.
 - d). The edges of existing pavement surface shall be cut smooth and vertical along a horizontal straight line. All saw cuts shall be square with existing pavement.
 - e). Remove all saw cut debris from the repair area. The base surface shall be finished smooth and rolled with a flat wheel, pneumatic tired roller or other compaction equipment to compact the uppermost portion of the repair area. Paved areas adjacent to the repair shall be cleaned by broom sweeping. The prime coat shall be applied at a rate of 0.40 gallons per square yard. The vertical edges of existing pavement shall be primed.
 - f). Bituminous asphalt shall be transported to the work site in vehicles with a cover over the cargo compartment to retard heat loss. The mixture shall be delivered at a temperature of 275°F to 325°F. The mixture shall be spread by hand or suitable machine immediately after delivery to the work site to a depth which will match adjacent pavement surfaces after rolling. The mixture shall be thoroughly compacted by passing a steel wheel roller over the surface course immediately after being spread. The mixture shall be continuously rolled until all roller marks are eliminated and no further compaction is possible. The final surface shall match adjacent pavement surfaces and there shall not be any depressions or raised surfaces across the repaired areas.
 - g). All preparatory work must be inspected by the ENGINEER before placement of asphaltic concrete.

24. TEMPORARY REPAIRS to PAVED SURFACES

- 24.1 Unless permanent repairs to paved street surfaces can be started within two (2) days after back filling the trench, the CONTRACTOR shall place suitable asphalt material in the trench. The surface shall match the surfaces on each side of the trench and shall be in accordance with applicable state, county, or local requirements.
- 24.2 The above provisions shall apply to driveways, sidewalks, parking lots, or other paved areas whenever the backfill will not adequately support vehicular traffic, whenever dust from the trench creates a nuisance, or whenever the trench is a hazard.
- 24.3 Detours shall have a gravel, crushed stone, or asphalt surface. Dust shall be controlled by the application of asphalt or water.
- 24.4 The CONTRACTOR shall maintain all temporary surfaces in good condition until permanent repairs are complete.

25. CONNECTIONS TO CWW DISTRIBUTION and COLLECTION SYSTEM

- 25.1 All connections to CWW existing distribution and collection system must be accomplished in the presence of the ENGINEER or his representative.
- 25.2 In cases where completing the connection will disrupt service to customers, the CONTRACTOR shall notify the ENGINEER at least two (2) days in advance of the work. The customers whose service will be disrupted shall be notified by the CONTRACTOR. The CONTRACTOR shall plan the work so that disruption of service is held to a minimum. The plan must be satisfactory to the ENGINEER.
- 25.3 After connections have been completed, the valves shall be tightly closed.

26. FILLING WATER PIPELINES

- 26.1 After the pipelines and appurtenances have been installed, all concrete thrust blocking has cured adequately and upon approval of the ENGINEER, the pipelines shall be filled with water.
- 26.2 In order to prevent circulation of water through the new pipelines back into the distribution system, only one valve shall be opened to allow water to flow into the new pipelines. This valve will be tightly closed after the filling operation has been completed.
- 26.3 The valve operated to fill the pipelines shall be operated slowly and shall not be fully opened. The valve shall be opened only enough to hear water flowing into the pipeline. This is determined by listening to the valve key after each full turn of the key. The operation of the valve shall be under the direction of the CWW Representative.
- 26.4 All air shall be expelled from the pipeline by opening fire hydrants, service lines and/or other openings installed at the pipeline crests by the CONTRACTOR. The location and number of such openings shall be as shown on the Plans or as directed by the ENGINEER.

27. CLEANING LARGE WATER PIPELINES

- 27.1 Before disinfection, hydrostatic pressure and leakage testing, pipelines 16-inches in diameter and larger shall be cleaned by forcing a resilient high density Polyurethane foam "cleaning pig" through each segment of the pipeline by water pressure to remove any dirt or other foreign matter from the pipeline. The "pig" shall be Blue Criss-Cross Polly Pig, manufactured by Knapp Polly Pig, Inc, Houston, Texas, or equal, in good condition and shall be at least two (2%) percent larger in diameter than the inside diameter of the pipeline being cleaned.
- 27.2 The "pig" shall be inserted in the first length of pipe installed in each segment of pipeline. After installation of the pipeline segment to be cleaned, the pipeline shall be filled at a point downstream of the "pig". The "pig" shall be forced through the pipeline by applying water pressure to the rear of the "pig" and opening blow-off valves or fire hydrants downstream of the "pig". Valves at blow-off points shall be closed immediately prior to the "pig" passing.
- 27.3 Based on past experience, the "pig" will negotiate bends and tees in the pipeline and may also be forced through the pipeline backwards after a pass forward. Openings in the pipeline, as shown on the Plans for removing the

Cabot WaterWorks Standard Construction Specifications

"pig", are based on this assumption. If the CONTRACTOR is unable to clean the pipeline, utilizing the openings provided, additional openings shall be provided by the CONTRACTOR, upon approval of the ENGINEER, at the expense of the CONTRACTOR.

- 27.4 If the need for more than one pass of the "pig" through the pipeline is indicated, the CONTRACTOR shall make additional passes as directed by the ENGINEER.
- 27.5 Drainage at blow-off points shall be provided so as not to create a nuisance and to avoid property damage.

28. HYDROSTATIC PRESSURE and LEAKAGE TESTS Water & Sewer Force Mains

- 28.1 After the CONTRACTOR has satisfied himself that the pipeline will pass a pressure and leakage test the CONTRACTOR shall contact CWW to witness the test.
- 28.2 At the direction of CWW' representative, the Contractor shall isolate sections of the pipeline, fill with water from a low point and release trapped air at crests through fire hydrants, service lines, air/vacuum relief valves or other openings installed by CONTRACTOR.
- 28.3 The CONTRACTOR shall furnish all labor, materials and equipment for conducting the tests.
- 28.4 CONTRACTOR shall provide a water pressure test pump for pressure and leakage test with the following features:
 - a). Designed for hydrostatic pressure and leakage test so the required test pressures can be attained.
 - b). By-pass pipe between the pump suction and discharge. By-pass shall be equipped with an in-line valve and a valve on the discharge.
 - c). Check valve arranged so as to prevent flow back toward pump.
 - d). Adjustable pressure regulating device capable of maintaining discharge pressure at a constant level.
 - e). Section of flexible hose - length sufficient that ends of hose rests on ground.
 - f). Straight meter coupling - 1/2" M.I.P. x 5/8" Meter Nut.
 - g). 5/8" meter - furnished by owner.
 - h). Straight meter coupling - 1/2" M.I.P. x 5/8" Meter Nut.
 - i). Connection for pressure gauge with valve and surge dampening device. Connection for gauge shall be 1/4" F.I.P. **CWW will furnish the meter and pressure gauge.**
 - j). Suction screen to prohibit entry of foreign matter if pump suction is connected to a vessel instead of on a water main.
- 28.5 The CONTRACTOR shall provide all other necessary materials for connecting the test pump from the suction source and to the main being tested.
- 28.6 The test pressure shall be a minimum **150 psi or the rated pressure class of the pipe material and not less than 1.5 times the working pressure at the lowest elevation of the pipeline being tested, as specified by CWW whichever is greater.** All pipelines and appurtenances shall be tested.
 - a). AWWA C900 PVC Pipe Rated Pressure for DR 18 – 235PSI, DR 14 – 305PSI
- 28.7 The duration of the hydrostatic pressure test shall be **two (2) hours** or as specified by the ENGINEER.
- 28.8 The source of water for the pump suction shall be potable water from CWW' distribution system. The vessel used must be approved by the ENGINEER.
- 28.9 All interior valves including valves on fire hydrants and other appurtenances shall be open during all tests.
- 28.10 After the specified test pressure has been applied, the entire pipeline shall be inspected in the presence of CWW' representative, particularly appurtenances that are exposed.
- 28.11 After the CONTRACTOR has taken the necessary action to repair or replace any part of the pipeline or appurtenances where leaks were apparent or if no leaks were apparent, the pipelines shall be subjected to a leakage test at the pressure specified with a meter inserted in the test pump discharge line.
- 28.12 At the end of the two hour pressure test the test pump shall be used to restore the pipeline pressure to the specified test pressure. Meter readings shall be taken before recharging the pipeline and after the pressure is

Cabot WaterWorks Standard Construction Specifications

restored to determine leakage. Alternatively to meter readings, the suction line of the test pump may be placed in a container with volume graduations to determine leakage amount. CWW shall approve container.

28.13 The maximum leakage per hour for ductile iron and PVC pipe shall be as calculated from the following formula:

$$Q = \frac{L * D * \sqrt{P}}{148,000}$$

- Q = Allowable Leakage (gallons per hour)
- L = Length of pipeline tested (feet)
- D = Nominal diameter (inches)
- P = Test pressure (psi)

For listed test pressures, the following table provides allowable leakage per 1000 feet of pipe in gallons per hour.

Nominal Pipe Dia Inches	Test Pressure - 150 psi	200 psi
	Allowable leakage per 1000 feet (gal/hour)	Allowable leakage per 1000 feet (gal/hour)
4	.33	.38
6	.50	.57
8	.66	.76
10	.83	.96
12	.99	1.15

28.14 When leaks are in excess of the above formula or table, the CONTRACTOR shall, at his own expense, perform whatever work and/or replace whatever material that is required in order to remedy the defect and stop the leaks. All corrective work shall be approved by CWW.

28.15 As directed by the Engineer, the Contractor shall perform follow-up pressure test on any lines that the Contractor has modified or disturbed after the initial pressure test.

29. FLUSHING WATER PIPELINES

29.1 Prior to disinfecting, all new pipelines shall be flushed to remove particulate. The flushing velocity in the pipe shall not be less than 2.5 ft./sec. The table below provides the required flow and number of 2” blow-offs and/or 2.5” fire hydrant nozzles opened to achieve the required flow for flushing.

Pipe Diameter Inches	Flow required for 2.5 ft./sec velocity to Flush new Pipe (gpm)	Number of 2” Blow-offs and/or 2.5” Fire Hydrants opened to achieve 2.5 ft./sec.
4	100	1
6	220	1
8	400	1
10	600	2
12	900	2
16	1600	3

29.2 The Engineer shall approve all flushing plans. The ENGINEER may halt or reduce flushing if the distribution system pressures are reduced by the flushing operations.

29.3 Flushing of new pipelines shall continue until no particulate is visible in the flushing discharge stream.

30. DISINFECTING WATER PIPELINES & APPURTENANCES

- 30.1 Prior to disinfecting water pipelines:
- a). Pipelines shall "PASS" a Hydrostatic Pressure & Leakage Test as specified previously in this document.
 - b). Pipelines shall be Flushed at 2.5 ft./sec.as specified previously in this document.
- 30.2 Disinfecting Water Mains shall be performed in accordance with AWWA C651 and the requirements of this Section.
- 30.3 Blow-off and sample points shall be constructed by the CONTRACTOR, as shown on the Plans or as directed by the ENGINEER. Fire hydrants shall be utilized as blow-off points whenever possible. Fire hydrants are not satisfactory for sample points. Openings for sample points shall be 3/4" or 1" copper riser pipe with a valve that is suitable for collecting bacteriological samples. A flushing plan shall be so designed so that all samples may be taken on each trip. Pipelines shall not be considered acceptable until two (2) consecutive bacteriological samples taken twenty-four (24) hours apart are negative.
- 30.4 There are two acceptable methods of disinfecting water mains: the *continuous feed method*, and the *slug method*. The slug method shall be used only on approval of the ENGINEER.
- a). **The "tablet method" specified in AWWA C651 is not permitted due to unequal distribution of disinfectant.**
 - b). Chlorine used for disinfection shall conform to ANSI/AWWA B300 or B301 and may be either liquid chlorine, sodium hypochlorite, and calcium hypochlorite.
- 30.5 The CONTRACTOR is reminded that chlorine is a powerful oxidant and reacts readily with foreign substances. All chlorine compounds shall be handled and stored in accordance with manufacturer's recommendations. Breathing of chlorine gas can be fatal. Hypochlorite solutions should not come into contact with skin or clothing. Containers used for mixing hypochlorite solution shall be clean and dry.
- 30.6 Backflow devices shall be installed to prevent chlorine solutions from back-flowing into the distribution system. Cabot Waterworks shall approve all backflow devices.
- 30.7 When the *continuous flow method* is used, the final concentration of chlorine inside the main shall be 25 mg/L.
- 30.8 Calcium hypochlorite shall contain minimum 65% available chlorine by weight either in tabular or granular form.
- 30.9 When the source of the chlorine is calcium hypochlorite, a solution of hypochlorite and water shall be prepared by mixing thoroughly in a suitable container. The mix shall contain one (1) pound of calcium hypochlorite per gallon of water. A suitable pump shall be provided for pumping this solution into the pipelines to be disinfected. This pump shall be equipped with a flow measuring device.
- 30.10 Liquid chlorine shall be used only when the CONTRACTOR has suitable equipment available and employees who are familiar with the physiological, chemical and physical properties and who are properly trained and equipped to handle any emergency that may arise.
- a). Liquid chlorine shall not be used if in the opinion of the ENGINEER, the equipment is inadequate or the personnel are not qualified.
 - b). When liquid chlorine is used, the equipment for injection shall consist of a solution feed chlorinator in combination with a booster pump for injecting the chlorine-gas and water solution into the pipeline.
 - c). Introduction of chlorine-gas directly from the supply cylinder shall not be permitted.
 - d). The booster pump shall be equipped with a flow measuring device.
- 30.11 The procedure for disinfecting by the *continuous flow method* shall be as follows:
- a). The flow through the pipeline and the solution flow shall be regulated so that the required concentration of chlorine is attained. The flow through the main shall be measured by using a pitot gauge or meter.
 - b). The introduction of the solution shall be continuous until the desired concentration is attained throughout the pipeline system. The concentration shall be checked by the Drop Dilution Method.

Cabot WaterWorks Standard Construction Specifications

- c). After the required concentration has been attained all internal valves shall be operated in order to assure that the solution comes in contact with all appurtenances.
 - d). The solution shall remain in the pipeline system for twenty-four (24) hours after which the pipelines shall be thoroughly flushed. The chlorine concentration shall be checked before flushing. If the concentration is less than 25 mg/L, the disinfecting procedure shall be repeated if directed by the ENGINEER.
- 30.12 When the *slug method* is used, the concentration of chlorine entering the pipeline shall be at least 100 mg/L.
- a). The free available chlorine residual shall be measured as the slug moves through the pipeline. If the free available residual drops below 50 mg/l, the flow shall be stopped and additional chlorine added to restore the slug to 100 mg/l free available chlorine.
- 30.13 The procedure for disinfecting by the *slug method* shall be the same as the continuous flow method except that the flow rates shall be regulated so that the specified concentration of chlorine shall be in contact with all parts of the pipe for at least three hours.
- 30.14 After final flushing, samples of water shall be collected by CWW from the sample points provided by the CONTRACTOR. The CONTRACTOR shall provide any assistance required in collecting the samples.
- 30.15 Water samples collected shall be tested for bacterial contamination. Bacterial Tests on water samples shall be performed by the Arkansas Department of Health.
- 30.16 If the Engineer deems necessary, water contaminate testing in addition to bacteriological may be performed. If the pipe and appurtenances are found to be contaminated by the actions of the Contractor, the Contractor shall be responsible for all costs to remove the contamination or replace the pipe and appurtenances at his cost.
- 30.17 If any of the samples collected have positive test results for bacterial contamination, the disinfecting procedures shall be repeated as directed by the ENGINEER until negative samples are collected. Only the continuous flow or slug method may be used.
- 30.18 The cost of water used for flushing after positive samples have been collected shall be deducted from amounts due the CONTRACTOR. The amount used shall be determined by measurements of flow using a pitot gauge. Payment shall be based on the lowest prevailing water rate.
- 30.19 CONTRACTOR shall pay CWW **\$100.00 per sample** for each positive sample collected to cover the cost of collecting and delivery of samples to the Arkansas Department of Health.

31. WATER METERS, SERVICE LINES and CONNECTIONS

- 31.1 Property corners shall be marked by a Licensed Surveyor prior to installing Service Lines and meter setters.
- 31.2 Services Lines including connections to water mains shall be installed at property corners, (including connections on the opposite side of the street) and outside of any paved surface.
- 31.3 Encasement pipe is required for service line road crossings. Encasement pipe shall be schedule 40 PVC or PE DR9.
- 31.4 The Contractor will be required at Contractors' expense to relocate or adjust meter & meter box elevation after final grading to conform to these specifications.
- 31.5 All requirements of SECTIONS 1-8 of these specifications shall apply for service line installations.
- 31.6 Service connections to water mains shall be installed with service saddles designed for the diameter pipe to be tapped. Mains to be tapped shall be a wet tap using a corporation stop threaded into the service saddle. The service saddle shall be installed so that the pipe will not be distorted when the saddle is tightened.
- 31.7 Service saddles shall be positioned so that the corporation stop will be directed between 15° to 30° from the horizontal spring-line of the pipe.
- 31.8 The CONTRACTOR shall furnish a service tapping machine that permits a shell-type cutting tool to be feed through the corporation stop with the main under pressure to cut a hole in the pipe. The pipe coupon shall be retained by the shell cutter and removed from the cutting tool after each tap.
- 31.9 Trenches shall be free of large or sharp stones, rocks, boulders, construction debris or frozen material to avoid damage to the buried pipes. If large stone is present, trenches shall be over-excavated at least 6" and pipe bedded with select granular material specified earlier in these specifications.
- 31.10 Service pipe shall be laid with sufficient slack to accommodate contraction of the pipe due to cooling, or expansion of the pipe. Service pipe must connect straight into each joint, and there must be no stress on the connection. Bends in the pipe must be no less than 10 pipe diameters from any fitting or valve.
- 31.11 Bending PEX service pipe shall be limited to a minimum radius of 20 pipe diameters.
- 31.12 Service pipe shall be installed with a minimum of 18" of cover. Top of water meters shall be set 6"-8" below finish grade. Top of meter boxes shall be set 1" above finish grade.
- 31.13 Meters shall be located in a meter box between curb and at lot lines. Meters shall not be placed on private property except along Arkansas Highway Right-of-way. Meter settings shall be installed at a location that is outside areas of vehicular traffic and paved surfaces and shall be accessible to Cabot Water Works. Meter boxes shall be approved by Cabot WaterWorks.
- 31.14 Meter setters shall be supported where required to keep the setter plumb.
- 31.15 Service lines and meters shall conform to typical details below.

Cabot WaterWorks Standard Construction Specifications

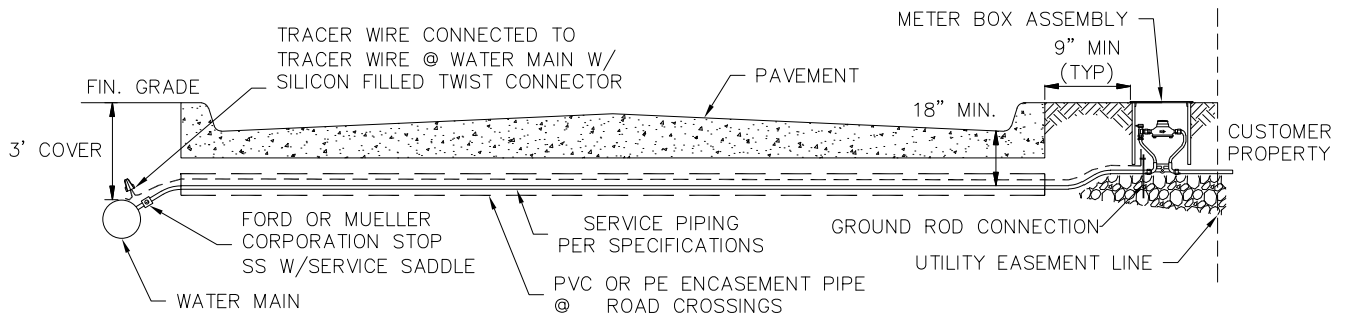

FORD (OR EQUAL) DUAL COPPERSETTER
 DUAL METER BOX WITH LID:
 DFW PLASTICS, INC.
 MODEL DFW39C-12-AF1C (5/8" & 3/4")

FORD (OR EQUAL) SINGLE COPPERSETTER
 SINGLE METER BOX WITH LID:
 DFW PLASTICS, INC.
 MODEL DFW1017-10-AF1EQ (5/8" & 3/4")
 MODEL DFW1219-10-AF1EQ (1")

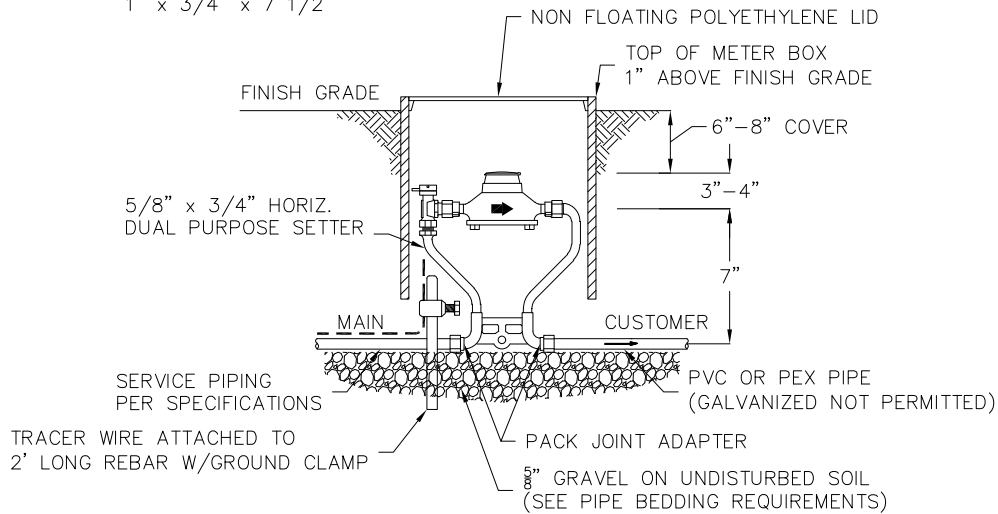
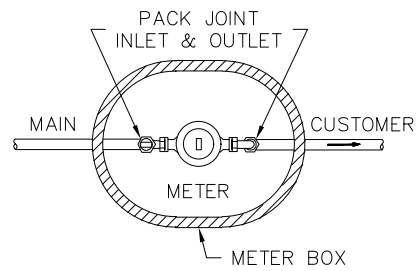
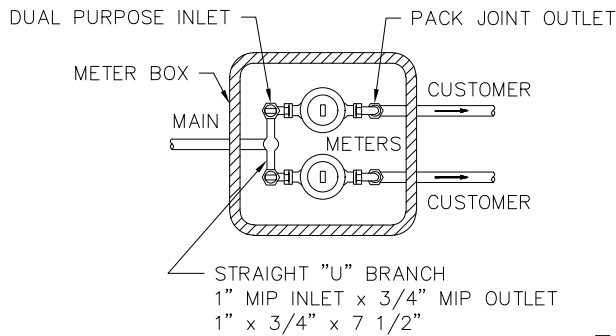

1. TRACER WIRE SHALL BE INSTALLED W/SERVICE LINE & WRAPPED AROUND TAPPING CORP. SEVERAL TURNS.
2. SERVICE LINE MATERIAL REMOVED FOR NEW CONSTRUCTION SHALL BE RETURNED TO CWW.
3. CUSTOMER METERS ARE NOT PERMITTED ON A.H.T.D. RIGHT-OF-WAY.
4. PRIOR TO INSTALLATION OF METERS, ALL SERVICE APPLICATIONS MUST BE COMPLETED AND APPROVED, SERVICE FEES PAID IN FULL AND AS-BUILT DRAWINGS SUBMITTED AND APPROVED.
5. METERS WILL NOT BE SET PRIOR TO A SUCCESSFUL BACTERIOLOGICAL TEST.
6. COPPER SETTER LAY LENGTH = $\frac{5}{8} \times \frac{3}{4}$ & $\frac{3}{4}$ - 7 $\frac{1}{2}$ " LAY LENGTH
 1" - 10 $\frac{3}{4}$ " LAY LENGTH

5/8", 5/8"x3/4", 3/4", 1" STANDARD SINGLE AND DUAL WATER METER SETTING DETAIL

Cabot WaterWorks Standard Construction Specifications

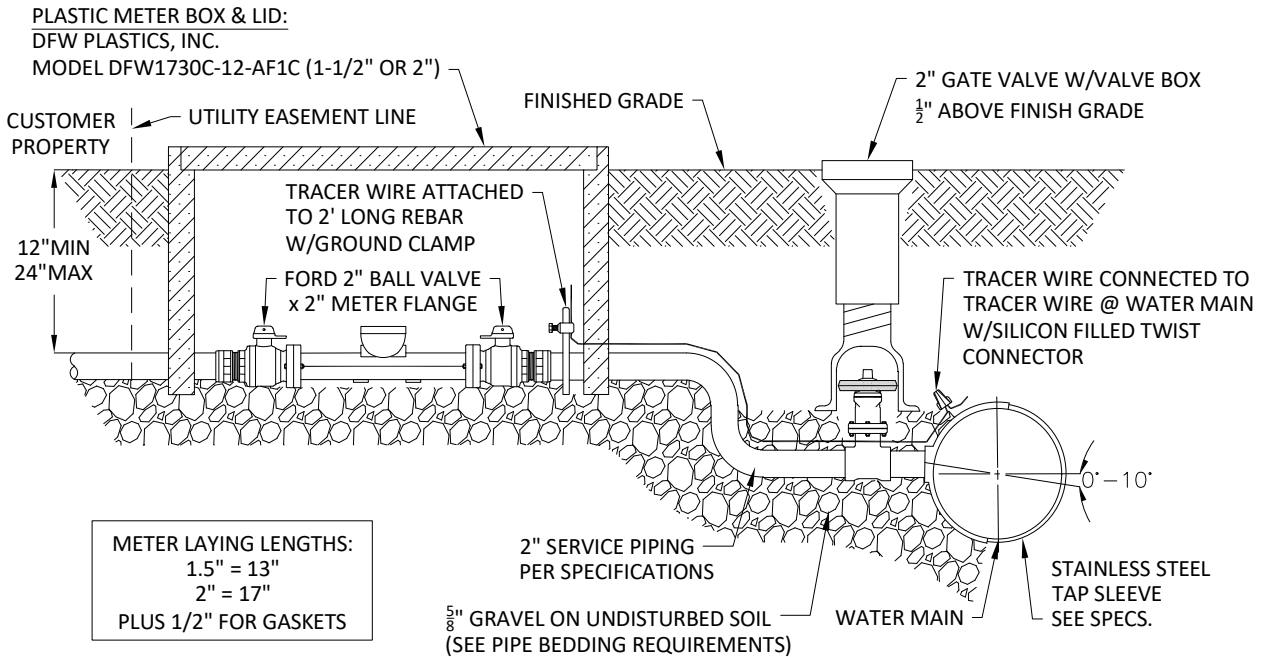

NOTES:

1. PRIOR TO INSTALLATION OF METERS, ALL SERVICE APPLICATIONS MUST BE COMPLETED AND APPROVED, SERVICE FEES PAID IN FULL AND AS-BUILTS SUBMITTED AND APPROVED.
2. METERS WILL NOT BE SET PRIOR TO DISINFECTION OF THE MAIN AND SUCCESSFUL BACTERIOLOGICAL TEST.
3. ALL METERS SHALL READ IN GALLONS, HAVE FLANGED ENDS.
4. METERS INSTALLED IN VAULTS SHALL BE EQUIPPED WITH REMOTE DISPLAY.
5. CABOT WATERWORKS WILL TAP MAIN AND SET METERS UP TO 2". CONTACT CABOT WATERWORKS FOR ASSOCIATED FEES.
6. CUSTOMER METERS ARE NOT PERMITTED ON A.H.T.D. RIGHT-OF-WAY.

1.5" AND 2" STANDARD WATER METER SETTING DETAIL

Cabot WaterWorks Standard Construction Specifications

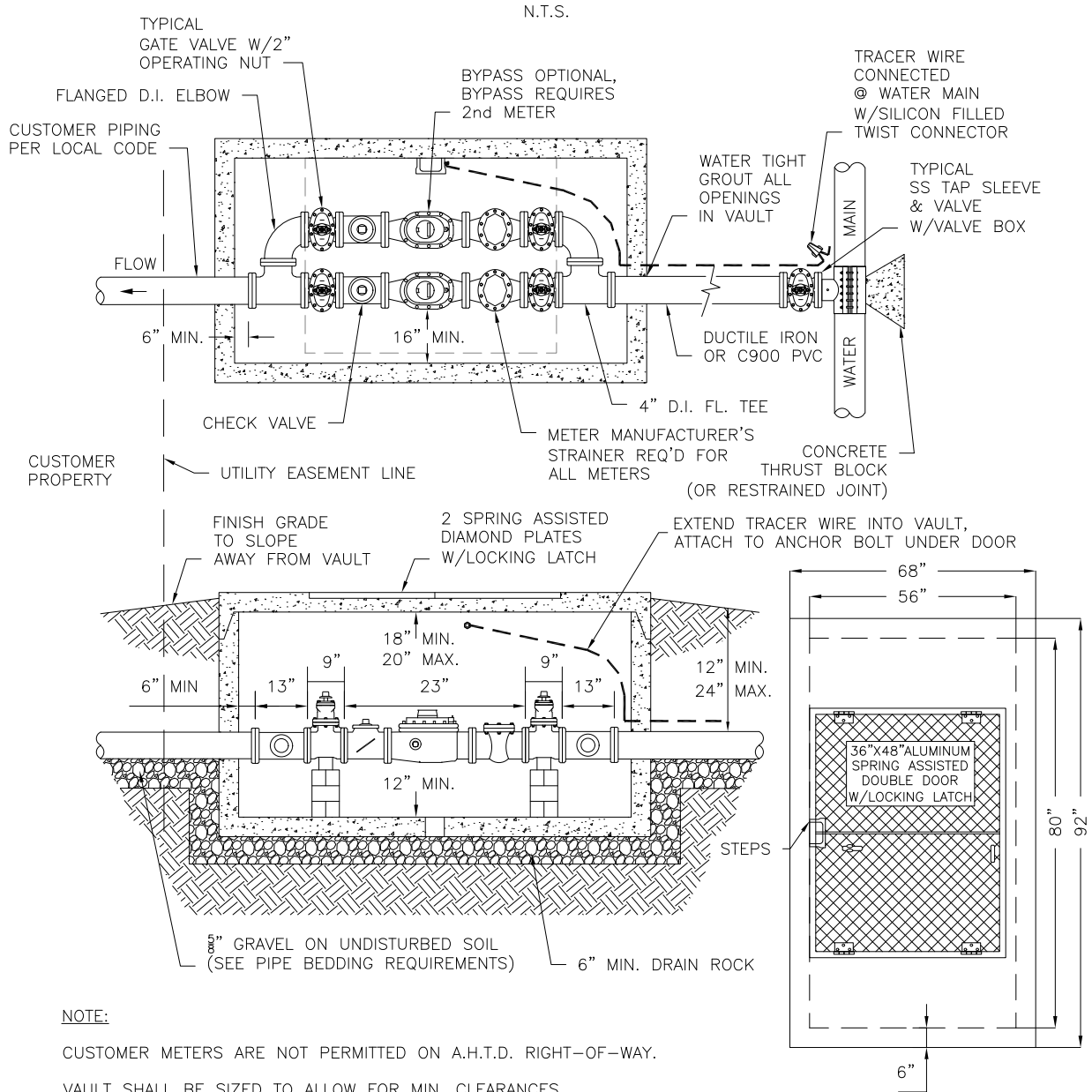

STANDARD 3" AND 4" NOMINAL SIZE METER INSTALLATION

32. SANITARY SEWER MANHOLES

- 32.1 Brick, masonry, and vitrified clay block manholes will not be accepted.
- 32.2 Pre-cast manholes shall conform to ASTM C478, “Standard Specification for Precast Reinforced Manholes”. Horizontal joints on precast manholes shall be sealed using a butyl mastic sealant conforming to ASTM C990. Acceptable Manufacturers: “NPC BIDCO C-56” butyl mastic sealant. The interior annular space at horizontal joints shall be grouted after installation with a non-shrink grout.
- 32.3 Concrete used in the construction of cast-in-place and pre-cast manholes shall have a 28-day compressive strength of at least 4,000 psi conforming to ASTM C94, “Standard Specification for Ready-Mixed Concrete” or ASTM C387, “Standard Specification for Packaged, Dry, Combined Materials for Mortar and Concrete”.
- 32.4 Concrete shall conform to requirements of “Concrete Mix – Placement & Finishing” of these specifications. Cold weather requirements for concrete in paragraph 22.25 shall apply for manholes.
- 32.5 Hydraulic-Cement Grout (non-shrink) used for installing pipe in manholes shall conform to ASTM C1107. Non-shrink grout shall be specially formulated to stop infiltration. Grout that has not been used within 30 minutes after water has been added shall not be used.
- 32.6 Manhole Rings and Lids shall be a minimum of 250 pounds combined weight with a 23 ½” diameter lid. Manhole lids shall have 2 inch tall, raised letters reading “SANITARY SEWER” cast into the lid. Lids shall have a pick bar and pick slot cast in the lid. Manhole lids with city names or any other lettering cast into the lid will not be accepted.
- 32.7 Stub-outs shall be constructed at the locations shown on the Plans. The stub-out shall be constructed in the direction and shall be the size and pipe material as shown on the Plans. The stub-out shall be bedded and backfilled as specified for sewer pipe used. After the stub-out installation is complete, watertight caps shall be installed on the end of the pipe. All stub-outs shall be pressure tested as specified for gravity sewers in these Specifications.
- 32.8 Pipe Connections to Manholes shall be made with a manhole adapter gasket conforming to ASTM C923 and designed to connect PVC sewer pipe to a concrete manhole wall. Manhole Adapter Gaskets shall be equal to Romac Style LCT or FERNCO Inc. and grouted or cast into manhole openings. Connections to Pre-cast manholes may optionally be made with Kor-N-Seal Pipe-to-Manhole Connectors or equal. All manhole connectors shall be installed in accordance with manufacturer’s recommendations. All interior annular space between pipe and manhole opening shall be filled with non-shrink grout conforming ASTM C1107.

EXECUTION:

- 32.9 Excavation for Manholes shall be limited to the area required for the manhole base. No extra payment shall be made for manhole excavation.
- 32.10 The concrete base shall have a minimum thickness of 6 inches measured from bottom of slab to bottom of all pipe connecting to the manhole and shall be poured on undisturbed earth. The base shall be poured so that the top of the concrete base outside the barrel is one-half of the pipe diameter of all pipes entering the manhole. The base shall extend 1 foot outside of the finished manhole barrel. Prior to pouring the base, any water in the excavation shall be removed, and the base poured in the dry. Reinforcement steel consisting of #4 rebar (1/4” inch diameter) shall be placed at mid depth in the base at 12inch centers in two directions.
- 32.11 Contractor shall support all pipe extending from the manhole barrel to undisturbed soil by filling under the pipe with Select Granular Bedding Material. All pipes entering a manhole shall extend to the interior surface of the manhole barrel.
- 32.12 The invert of the manhole shall be benched and hand shaped with concrete as specified. The base and barrel of the manhole shall be cleaned thoroughly prior to placement of the benched invert. Benches shall be shaped and sloped ½ inch/foot from the manhole barrel wall down to ½ of the inside pipe diameter. The entire diameter of each pipe entering the manhole barrel shall be cut smooth with the inside surface of the manhole barrel and the invert shaped smooth from all inlet pipes to the outlet pipe. The flow channels in the invert shall be contoured to the inside diameter of all pipes entering and exiting the manhole. Flow channels shall have the same slope between inlet and outlet as the connected pipe.

Cabot WaterWorks Standard Construction Specifications

- 32.13 Manhole Barrels. The minimum thickness of manhole barrels shall be 6 inches. The barrel may be poured monolithically with the base, or the barrel forms may be set as soon as the concrete base has cured enough to support the forms. Barrel forms shall be set plumb and properly braced prior to pouring concrete. Vibration equipment shall be used while pouring the barrel walls to eliminate voids in the concrete barrel wall.
- 32.14 All manholes shall be 4 feet inside diameter, except where larger diameter manholes are called for on the Plans.
- 32.15 Prior to setting the manhole barrel forms in place, any water that may have accumulated in the excavated area shall be pumped out and the concrete base thoroughly cleaned of dirt and debris. All concrete shall be poured in the dry.
- 32.16 Construction joints shall be provided with a keyway as shown on the detail and shall have a 2 inch layer of grout applied to the previous pour immediately before the next wall lift is poured.
- 32.17 The cast-in-place forms may be removed after the initial set of the concrete so that holes may be cut in the manhole barrel for the installation of pipes which are to enter the manhole at points other than adjacent to the manhole base. After these pipes have been put in place, the barrel shall be repaired using a non-shrink grout mixture conforming to ASTM C1107.
- 32.18 After removal of the forms all honeycombing, imperfections and depressions found in the barrel wall shall be immediately filled with mortar and rubbed with a wooden float or steel trowel to give a uniform appearance. Spurs shall be removed from the concrete surface.
- a). Barrels exposed above grade shall be hand rubbed as required. Wet and fill all voids using mortar with the same sand-cement ratio as original concrete. Blend cement to match concrete color. Strike off all excess mortar flush with the surface using a burlap or canvas cloth with a circular motion. Remove all rough spots and rub with cloth to leave a surface of uniform texture and appearance. Finish shall result in a coating of mortar that will fill all voids and air holes, leaving a smooth surface.
- 32.19 Manhole steps are required for manholes over 4 feet deep. Steps shall be resistant to corrosion from hydrogen sulfide and sulfuric acid.
- 32.20 Top of manholes shall be constructed 1 foot above finished grade; 1 foot above flood elevation and/or 1 foot above peak storm flow elevation when located adjacent to open storm drainage channels. Exception: Top of manholes located at high elevations that will not collect storm water runoff, may be constructed 2" above finished grade.
- a). Cabot Waterworks may consider bolted water tight manhole lids as an option.
- b). Finish grade shall slope away from manholes, (including any paved surface)
- c). Top of manholes located in paved surfaces shall be set at the final grade of the paved surface.
- 32.21 Manholes shall be installed at the end of each line and spaced at distances no greater than 600 feet.
- 32.22 Drop manholes, unless otherwise shown on the Plans, shall be constructed at all manholes where the difference in invert elevation between incoming and outgoing sewer is 2 feet or more. Drop manholes shall be constructed of the same material and dimensions as are standard manholes, the only difference being in the inlet arrangements as shown on the standard detail.
- 32.23 Curing compounds or covers may be used at the option of the Contractor. However, it will be the responsibility of the Contractor to protect the concrete to prevent cracking during the curing process and to protect the manhole during freezing temperatures. The Engineer shall, at his discretion, prohibit pouring concrete during periods of extreme cold or inclement weather.
- 32.24 Manholes shall be backfilled only after 48 hours of concrete curing time. Extra care shall be taken to compact all backfill evenly around the perimeter of the manhole to the top of the highest pipe entering the manhole. Backfill material shall conform to pipe bedding as specified elsewhere in these Specifications.
- 32.25 All manholes constructed shall be watertight and show no visible evidence of infiltration.
- 32.26 Manholes shall pass a vacuum test in accordance with ASTM Designation C1244
- a). Vacuum Test. All incoming and outgoing sewer mains shall be plugged for vacuum test. Service line stub-outs shall be capped outside manhole and open inside manhole for vacuum testing. The Contractor shall furnish a suitable manhole vacuum testing apparatus, such as manufactured by P. A. Glazier, Inc., made for

Cabot WaterWorks Standard Construction Specifications

such purpose. The test shall be performed by drawing a vacuum of 10" of mercury (Hg) (equivalent to 5 PSI vacuum) and measuring the time for a drop to no less than 9" Hg, (½ PSI vacuum drop). The time measured shall not be less than indicated in the table below for a 1.0" Hg, (½ PSI) drop in vacuum.

Depth of MH (feet)	Time in seconds for 1.0" Hg (1/2 PSI) loss of vacuum		
	48" Diameter	72" Diameter	96" Diameter
4'	10	16	23
6'	15	25	34
8'	20	33	45
10'	25	41	56
12'	30	49	67
14'	35	57	78
16'	40	67	89
18'	45	73	100
20'	50	81	111

- b). For all manholes with leaks in excess of the above, the CONTRACTOR shall, at his own expense, perform whatever work and/or replace whatever material that is required in order to remedy the defect and stop the leaks. All corrective work shall be approved by CWW.
- c). Manholes which fail the test shall be retested after remedial measures are completed.

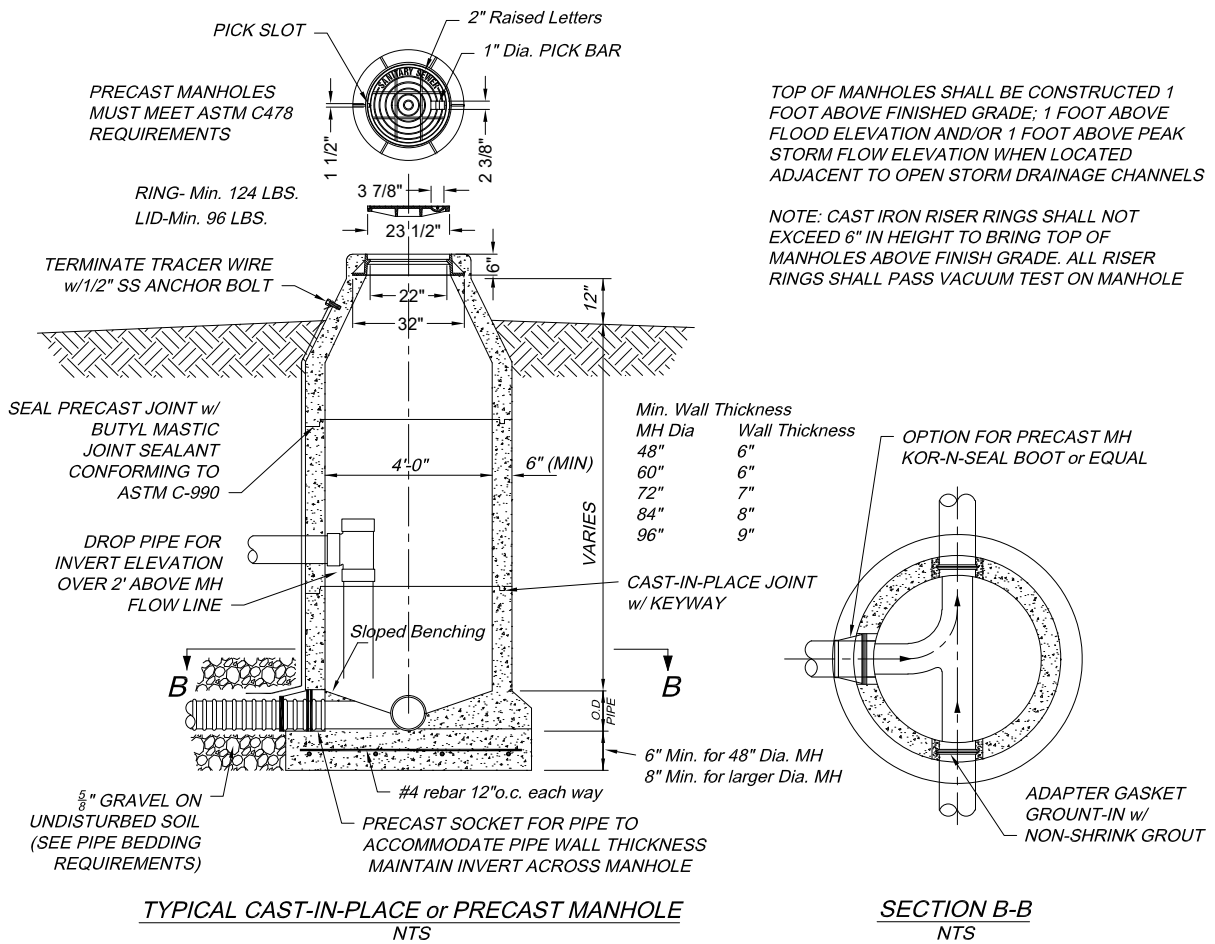

Cabot WaterWorks Standard Construction Specifications

33. Sanitary Sewer Gravity Pipelines

- 33.1 All requirements for **Pipe Bedding & Backfill**, including Tracer Wire and marking tape, in these specifications shall apply to Sanitary Sewer Pipelines.
- 33.2 Contractor shall support all pipes from manholes to undisturbed soil by filling under the pipe with Select Granular Bedding. Backfill shall be placed as specified in these Specifications.
- 33.3 All joints shall be of the bell and spigot type and conform to ASTM D3212 and/or Uni-Bell UNI-B-1. Gaskets shall be in accordance with ASTM F477. All bells shall be formed integrally with the pipe and shall contain a factory installed elastomeric gasket which is positively retained. Wall thickness of this bell at any point shall not be less than the required minimum for the pipe barrel. No solvent cement joints will be permitted except as specifically authorized by the Engineer.
- 33.4 Gasket lubricants shall be supplied as per the pipe manufacturer recommendations. Contractor shall provide documentation that gasket lubricants are approved by the manufacturer for the pipe and gaskets used on the project. Lubricants shall be applied as per pipe manufacturer's recommendation.
- 33.5 Construction Sequence. Construction of sewers shall begin at the low point of the line and continue in orderly succession throughout the project. Any deviation from this procedure shall be made only with the specific approval of the Engineer. Pipe shall be laid with bell ends facing the direction of laying upgrade.
 - a). Sewer pipe shall be installed on a uniform slope between manholes at the grade indicated on plans using a pipe laser specifically designed for installing pipelines on grade.
- 33.6 Connections to new manholes shall conform to requirements for "Sewer Manholes" in these specifications.
- 33.7 Existing Manholes. Connections to existing manholes or inlets, where pipe stubs exist, shall be made by cutting a hole in the wall of the existing manhole, inserting the PVC pipe with a manhole adapter around the pipe into the hole, filling the annular space around the pipe with non-shrink grout, and troweling the inside and outside surface to a smooth finish. The bottom of the manhole shall be shaped to fit the invert of the sewer pipe.
- 33.8 Mandrel Testing. Gravity PVC sewer mains shall be tested for deflection in accordance with ASTM D2321.
 - a). Mandrel test shall not be performed for at least 30 days after reaching final trench backfill grade, provided, in the opinion of the Engineer, that sufficient ground settlement has occurred throughout the entire trench depth. If this has not been achieved prior to the project completion date, then the Mandrel size shall be increased to measure one-third less of a deflection allowance.
 - b). The Mandrel shall be a rigid device sized to pass 5 percent or less deflection (or deformation) of the pipe and shall be cylindrical in shape with a minimum of 9 evenly spaced arms or prongs. Mandrels with fewer arms will be rejected as not sufficiently accurate. The contact length of the Mandrel's arms shall equal or exceed the nominal diameter of the sewer to be inspected. Critical Mandrel dimensions shall carry a tolerance of plus or minus 0.01 inch.
 - c). Inside pipe dimensions specified in the applicable ASTM pipe standards, shall be used to compute the Mandrel dimensions.
 - d). The Mandrel shall be hand-pulled by the Contractor through all sewer lines. Any sections of sewer not passing the Mandrel shall be uncovered and the Contractor shall re-bed, re-round or replace the sewer pipe to the satisfaction of the Engineer. These repaired sections shall be retested.
 - e). Drawings of the Mandrel with complete dimensioning shall be furnished by the Contractor to the Engineer for his approval for each diameter and specification of pipe.

Cabot WaterWorks Standard Construction Specifications

33.9 Low Pressure Air Testing for Sewer Lines.

- a). After ALL underground utilities have been installed, (Electric, gas, phone, cable, etc.), Contractor shall perform low pressure air test on all gravity sewer lines in accordance with ASTM F1417.
- b). The equipment required for the test shall include a regulator to avoid over-pressurizing and possibly damaging an otherwise acceptable line. The equipment used shall be Air-Loc system as manufactured by Cherne Industrial, Inc., Hopkins, Minnesota, or equal.
- c). The low pressure air test shall be conducted by plugging each opening in the reach of pipe to be tested. All plugs shall be braced against slippage due to internal pressure, and no one shall be allowed in the manhole during the testing procedure. One of the plugs provided must have an inlet tap or other provision for connecting an air hose.
- d). Service lines connected to the pipe to be tested shall be capped with an air tight cap that will withstand air pressure to be applied.
- e). After connecting the air control equipment to the air hose, monitor the air pressure so that the internal pressure does not exceed 5.0 psig. After reaching 4.0 psig, the air supply shall be throttled to maintain between 4.0 and 3.5 psig for at least 5-10 minutes in order to allow the air temperature to equalize inside pipe walls. The time required for the air temperature to equalize will depend on differential air temperature from the compressor to inside the pipe. If plugs are found to leak, the Contractor shall bleed off the air, tighten the plugs, and again begin supplying air. After the temperature has stabilized, the pressure is allowed to decrease to 3.5 psig. At 3.5 psig, the Contractor shall begin timing to determine the time required for the pressure to drop to 3.0 psig. The pipe shall be presumed free of defects if the time, in seconds, for the air pressure to decrease from 3.5 psig to 3.0 psig is greater than that shown in the table shown on the following page.
- f). Any test section less than 100 feet in length shall be tested for the time set out for 100 feet.
- g). If by use of the above procedure, defective section(s) of pipeline are found, the pipeline segment shall be tested at 20 foot intervals to determine the exact location of the defect(s). Repairs shall be made in defective section(s) and the entire line segment shall then be retested.

**SPECIFICATION TIME REQUIRED FOR 0.5 PSIG PRESSURE DROP
FOR SIZE AND LENGTH OF PIPE INDICATED FOR Q = 0.0015**

Pipe Dia. (in.)	Min. Time (min:sec)	Length for Min. Time (ft)	Time for Longer Length (sec)	Specification Time for Length (L) Shown (hr:min:sec)										
				100	150 ft.	200 ft.	250 ft.	300 ft.	350 ft.	400 ft.	450 ft.	500 ft.	550 ft.	600 ft.
8	3:47	298	.760L	0:03:47	0:03:47	0:03:47	0:03:47	0:03:48	0:04:26	0:05:04	0:05:42	0:06:20	0:06:58	0:07:36
10	4:43	239	1.187L	0:04:43	0:04:43	0:04:43	0:04:57	0:05:56	0:06:55	0:07:55	0:08:54	0:09:54	0:10:53	0:11:52
12	5:40	199	1.709L	0:05:40	0:05:40	0:05:42	0:07:07	0:08:33	0:09:58	0:11:24	0:12:49	0:14:15	0:15:40	0:17:05
15	7:05	159	2.671L	0:07:05	0:07:05	0:08:54	0:11:08	0:13:21	0:15:35	0:17:48	0:20:02	0:22:15	0:24:29	0:26:43
18	8:30	133	3.846L	0:08:30	0:09:37	0:12:49	0:16:01	0:19:14	0:22:26	0:25:38	0:28:51	0:32:03	0:35:15	0:38:28
21	9:55	114	5.235L	0:09:55	0:13:05	0:17:27	0:21:49	0:26:11	0:30:32	0:34:54	0:39:16	0:43:37	0:47:59	0:52:21

33.10 ACCEPTANCE INSPECTION BY CCTV: Before acceptance of gravity sewer pipelines by CWW, gravity sewer line segments shall be inspected for final acceptance by CCTV.

- a). CCTV inspection shall be performed at Contractors expense after all underground utilities have been installed, (Electric, gas, phone, cable, etc.),
- b). A Cabot Waterworks representative shall be present during the CCTV inspection.
- c). Sewer Mains shall be flushed and all debris removed prior to CCTV inspection.
- d). After Sewer Mains are flushed, the pipe shall be flooded with adequate water to fill low spots to verify pipe is on grade.
- e). All sections of sewer pipe that fail to drain after flushing or have trapped or standing water in excess of 1/4" in depth will be considered defective work and shall be corrected by the Contractor prior to acceptance. The

Cabot WaterWorks Standard Construction Specifications

Contractor shall repair any misalignment, displaced pipe, or other conditions which deviate from those specified.

- f). The television camera used for the inspection should be designed and constructed specifically for such inspection, producing a highly legible picture. The camera shall be operative in conditions 100% humidity and/or under water. The lighting and camera quality shall be suitable to allow a clear, in focus picture of a minimum of 6 linear feet of the entire inside periphery of the sewer pipe.
- g). Picture quality and definition shall be to the satisfaction of Cabot Waterworks.
- h). The section of gravity sewer line being inspected shall be isolated from the remainder of the sewer line as necessary. The Contractor shall make all provisions for pumping or bypassing the flow around the manhole section as required and the cost shall be incidental to the CCTV inspection.
- i). The camera shall be moved through the sewer line in either direction at a uniform slow rate not to exceed 60 feet per minute. Under no circumstances shall the camera be tethered to a hydraulically propelled or high velocity jet cleaning device while the cleaning device is on.
- j). The camera shall stop at each service connection and provide a view up the service line.
- k). Contractor shall not be allowed to float the camera.
- l). The Contractor shall furnish DVD's of the lines televised to CWW for review and comments, which may require up to 30 calendar days from the date submitted. Each DVD shall be labeled with the following information:
 - Project Job Number
 - Manhole to Manhole Designation
 - Date Televised
 - Street or Other Location
- m). The DVD recordings shall log the following information:
 - Project Job Number (or Subdivision Name)
 - Name of Contractor
 - Date Televised and Continuous Distance Log (measured in feet)
 - Street or Other Location
 - Upstream Manhole Designation
 - Downstream Manhole Designation
 - Pipe Material and Diameter
 - Direction of Televising (Downstream or Upstream)
- n). DVD's shall become the property of the CWW and will be retained by the CWW.
- o). If the DVD's are of such poor quality that CWW is unable to evaluate the condition of the sewer line or to locate service connections, the Contractor shall be required to re-televising and provide a good quality DVD of the sewer line at no additional cost to CWW.
- p). All sections of sewer lines considered unacceptable shall be repaired using new materials. The cost of such repairs shall be the responsibility of the Contractor.
- q). Cabot Waterworks shall make no payments for repair of unsatisfactory or defective work.

34. Wastewater Service Connections

- 34.1 All requirements for **Pipe Bedding & Backfill**, including Tracer Wire and Marking Tape, in these specifications shall apply to wastewater service lines.
- 34.2 Service pipe material shall conform to ASTM D 2665, Schedule 40 DWV. The minimum diameter for service pipe shall be 4".
- 34.3 Building sewer service lines connecting to Cabot WaterWorks sewer system shall be sized and installed in accordance with the Arkansas Plumbing Code.
- 34.4 Cabot WaterWorks shall be notified prior to any connection to the Cabot WaterWorks sewer system. All building sewer service lines and connections to Cabot WaterWorks sewer system shall be inspected by CWW prior to covering or backfilling the connection.

Cabot WaterWorks Standard Construction Specifications

- 34.5 Wastewater service connections shall be made at manholes where possible. Service connections at manholes shall conform to all requirements of pipeline connections to manholes in these specifications.
- a). Service connections to manholes shall be made at an elevation above the manhole invert of at least $\frac{2}{3}$ the main line pipe diameter though not more than 24”.
- 34.6 Contractor shall install service wyes and stub-out sewer service lines to every building lot in new subdivision construction. Service wyes shall conform to ASTM D3034, SDR-26. Service stub-outs shall be capped with water tight caps. No plugs will be permitted. Service stub-outs shall be subjected to pressure test when the sewer main is tested.
- a). The end of Service line stub-outs shall be marked with a green steel fence post with a 2 ½” PVC pipe slipped over the post with “Sewer Pipeline” stenciled on the PVC pipe in green color. Alternatively a 66” tall, green colored fiberglass marker labeled “Sewer Pipeline” maybe installed at the end of the service stub-outs. The markers shall not be disturbed during construction on the lot.
- 34.7 Service connections to existing sewer mains shall be performed using a service saddle. Service saddles shall be ROMAC Industries Style “CB” or equal. Service saddles shall conform with the following requirements:
- The saddle body cast from ductile iron, meeting ASTM A536, Grade 65-45-12 with epoxy coating.
 - Gasket from virgin Styrene Butadiene Rubber (SBR) in accordance with ASTM D 2000 MBA 710.
 - A pipe stop molded into the inside wall of the gasket and rated for 1000 lbs. of force along the branch.
 - A Stainless Steel strap, type 304 (18-8), 3 1/2 inches wide
 - Bolts and nuts Type 304 (18-8) Stainless Steel 1/2" National Coarse roll thread.
 - Rated for a 7 psi air test when properly installed.

Cabot WaterWorks Standard Construction Specifications

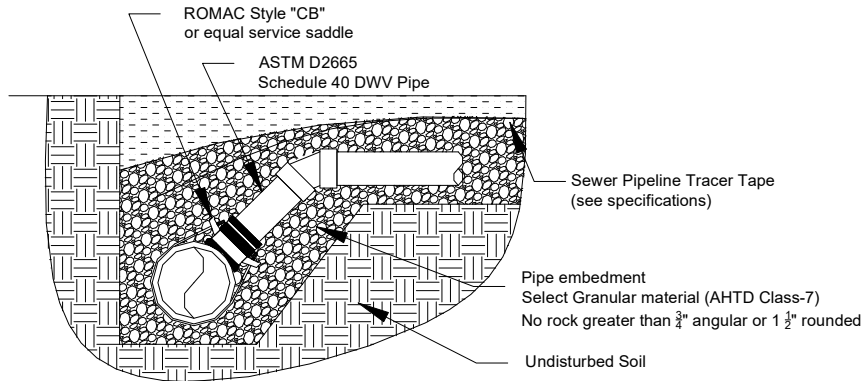

Typical Sewer Service Connection to Existing Sewer Main

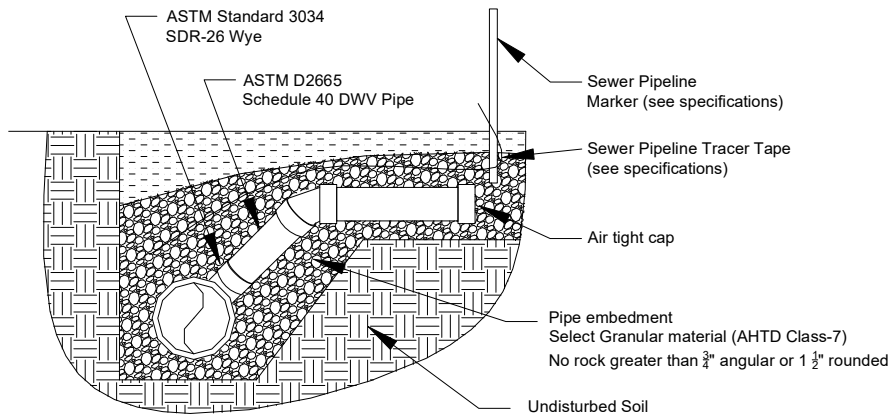

Typical Sewer Service Connection to New Sewer Main

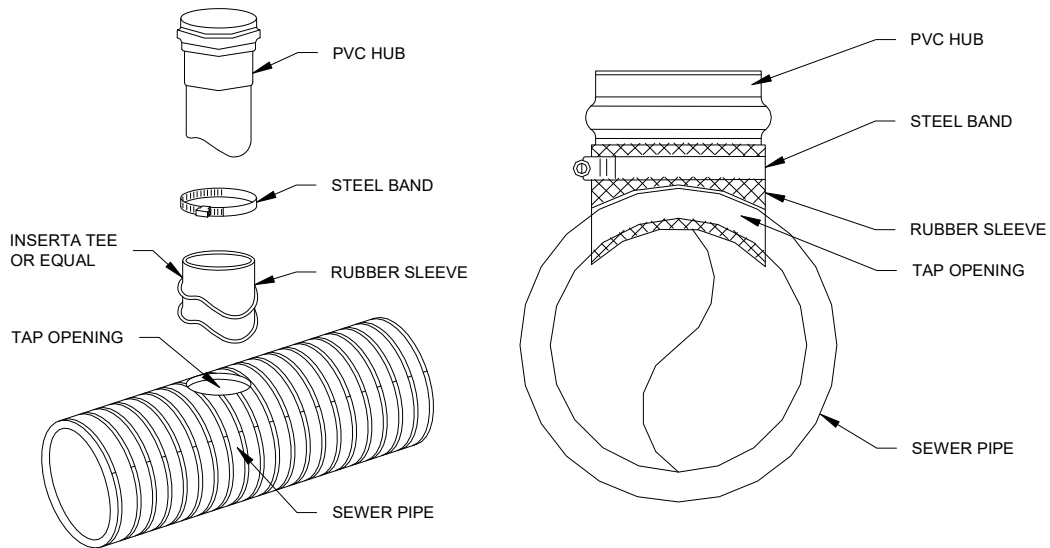

COMPRESSION FIT 3-PIECE SERVICE CONNECTION
(FOR 15" + LARGER DIA. CORRUGATED PVC/PE PIPE ONLY)

Cabot WaterWorks Standard Construction Specifications

34.8 Service Saddles shall be installed in accordance with manufacturer's recommendations. As directed by the Engineer, Contractor shall pressure test service connections in accordance with Low Pressure Air Testing for Sewer Lines of these specifications.

34.9 Sewer cleanouts shall be located to minimize damage to the cleanout.

- a). Sewer cleanouts shall be located to prevent stormwater from entering the sanitary sewer.
- b). Sewer cleanouts in paved surfaces shall conform to the detail below.

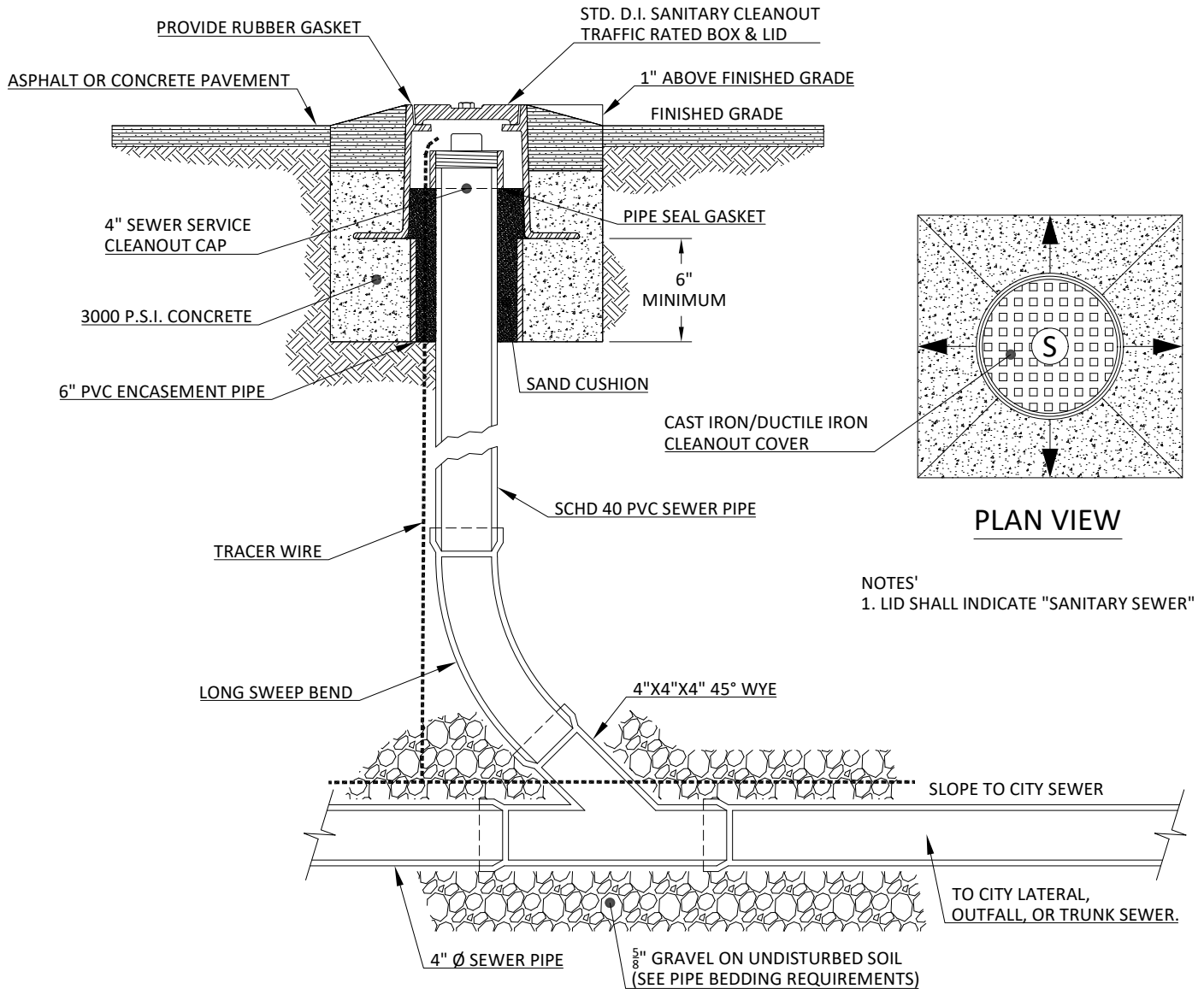

NOTES'
1. LID SHALL INDICATE "SANITARY SEWER"

35. Connections to Existing Sewer Service Lines

35.1 Connections to existing sewer service lines shall be made with flexible rubber couplings with shear rings to provide watertight connections to clay, concrete and bituminous fiber pipe, commonly referred to as

Cabot WaterWorks Standard Construction Specifications

“Orangeburg”. Connections to existing piping shall be bedded in accordance with the section for “Pipe Bedding and Backfill” in these specifications.

36. Grease Traps and Grease Interceptors

- 36.1 Grease traps and grease interceptors shall be installed as required by the Arkansas State Plumbing Code and Cabot WaterWorks.
- 36.2 Traps shall be installed no less than 10 ft. from sinks and dishwashers to allow for cooling of the wastewater. Water temperatures should be less than 140 degrees prior to entering grease trap. All grease bearing waste streams shall be routed through a grease trap or interceptor, including: three-compartment sinks, pot/pan sinks, hand-washing sinks, dishwashers, mop sinks and floor drains.
- 36.3 Grease traps shall have two compartments and constructed of pre-cast concrete. Very large units may be cast-in-place. Manholes to finished grade shall be provided. Cabot WaterWorks requires approval of the design of grease traps before the grease trap is purchased or installed.
- 36.4 Grease traps shall be placed on undisturbed earth. Prior to installing, any water in the excavation shall be removed, and the tank set in the dry.
- a). Top of Manholes and Cleanouts shall be set to prevent stormwater from entering the sanitary sewer.
- 36.5 The minimum capacities of grease traps shall be from the EPA Design method below for restaurants and commercial kitchens, though not less than 1000 gallons.
- $$(M) \times (GL) \times (ST) \times (2.5) = \text{Size of Grease Trap in gallons.}$$
- Where:
- M = Meals per day
- GL = Gallons of wastewater per meal, normally 4.5 gal
- ST = Storage capacity factor -- minimum of 1.7
- For a restaurant or kitchen preparing 100 meals per day, the minimum size of grease trap will be as follows, (100) x (4.5) x (1.7) x (2.5) = 1900 gals.**
- 36.6 The grease interceptor tank may be sized by using the peak design flow rates for all fixtures leading to the grease interceptor. A minimum retention time of 30 minutes shall be used to size the grease interceptor tank.
- 36.7 Grease trap construction shall conform to **ASTM C1613, Standard Specification for Precast Concrete Grease Interceptor Tanks and the typical detail below.**
- 36.8 Grease traps shall pass a vacuum test in accordance with **ASTM C1613.**
- a). Vacuum Testing—Seal empty tank and apply a vacuum of 4 in. (100 mm) of mercury. Hold the vacuum for 5 minutes. During the initial 5-minute period, the vacuum shall not drop more than ½ in. (13 mm) of mercury, to allow for temperature and pressure equalization. After 5 minutes, the vacuum shall be brought back to 4 in. (100 mm) of mercury and held for 5 minutes with no vacuum loss. If the tank fails the test, it shall be repaired and retested.

Cabot WaterWorks Standard Construction Specifications

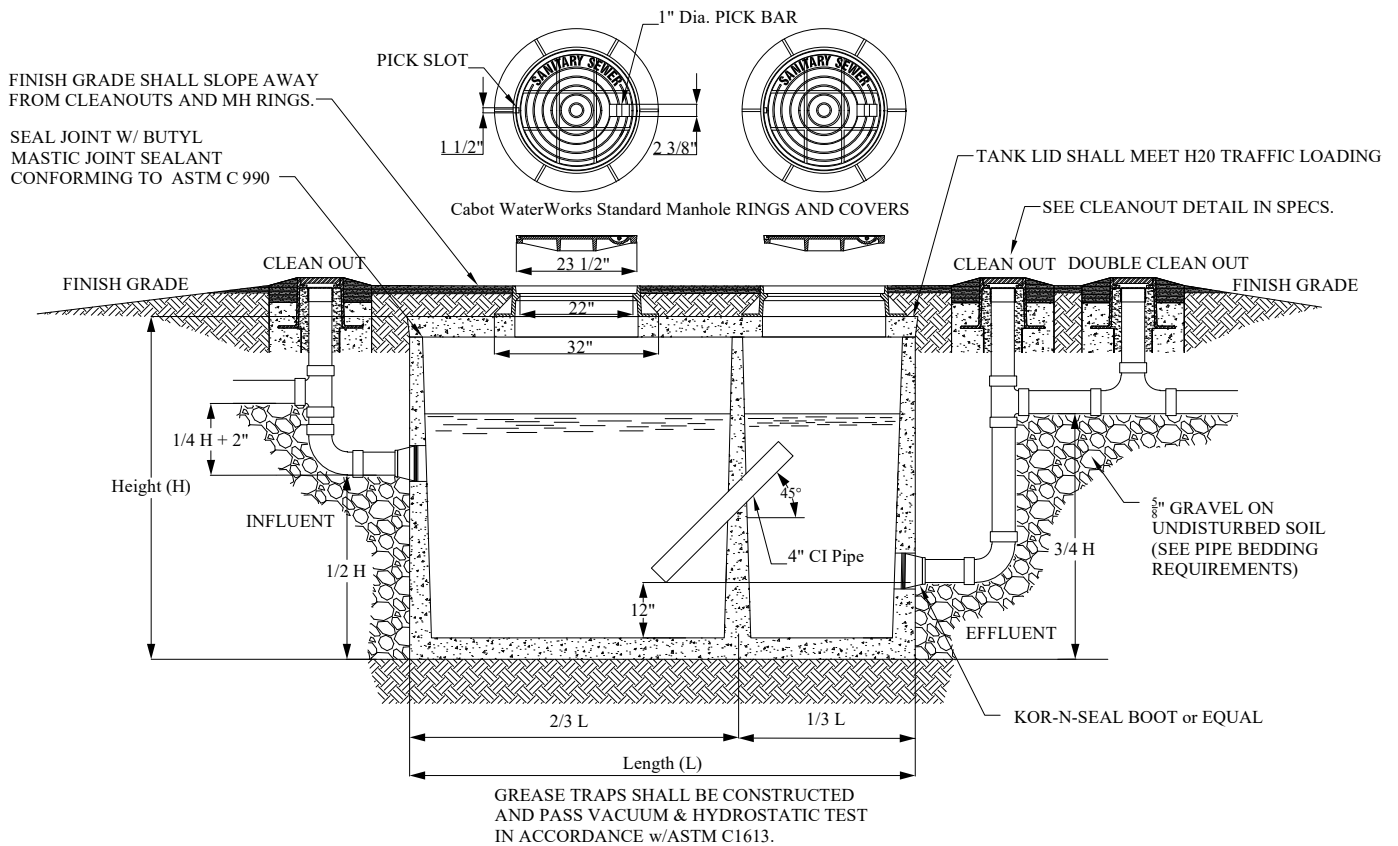

Typical Grease Trap Detail

37. Oil Separators and Grit Interceptors

- 37.1 Oil separators and sand (grit) interceptors shall be installed as required by the Arkansas State Plumbing Code and the Recommended Standards for Wastewater Facilities. The Minimum Tank size shall be 1000 gallon.
- 37.2 Oil and Grit removal tanks shall be designed to control velocities during normal variations in flow as close as possible to 1 foot per second. Detention time in the tank should be 5 minutes at design peak hourly flows.
- 37.3 Where automobiles and machinery are serviced, greased, repaired or washed, oil and grit interceptors shall have a capacity of not less than 6 cubic feet for the first 100 square feet of area to be drained, plus 1 cubic foot for each additional 100 square feet of area to be drained into the interceptor.
- 37.4 Plans shall be submitted to Cabot WaterWorks and approved prior to construction, for facilities requiring Oil separators and Grit interceptors.
- 37.5 Grit removal should be provided prior to entering the oil-water separator compartment for the removal of total suspended solids. Allow space for accumulated grit between the expected grit removal maintenance cycle. Access should be provided for a truck with suction equipment to periodically remove grit.
- 37.6 Oil separators and grit interceptors shall pass a vacuum test in accordance with the Section 0, of these specifications for vacuum testing sanitary sewer manholes.

Cabot WaterWorks Standard Construction Specifications

38. Wastewater Pump Stations

- 38.1 Pump operating conditions, design calculations shall be submitted by a Professional Engineer to Cabot Waterworks for approval prior to pump procurement. Pumps will not be accepted by Cabot WaterWorks until pump sizing calculations have been approved by Cabot WaterWorks.
- 38.2 Wastewater pumpstations shall conform to the most current addition of the “RECOMMENDED STANDARDS FOR WASTEWATER FACILITIES” published by Great Lakes - Upper Mississippi River Board of State and Provincial Public Health and Environmental Managers, (10 States Standards).
- 38.3 SUBMERSIBLE WASTEWATER PUMPS
- Pump manufacturer shall be submersible 3 phase 480v FLYGT N-Series self-cleaning semi-open channel impeller or equal and classified as non-clog with submersible cable. Pumps connected to force-mains less than 4” in diameter shall be grinder pumps.
 - Pump manufacturer must have an authorized service center within 50 miles of Cabot.
 - Provide Cabot Waterworks pump equipment submittals that include pump curves, warranty, and dimensional drawings with installation procedures for approval.
 - A control system shall be supplied by the pump manufacturer containing all the mechanical and electrical equipment necessary to provide for the operation of the submersible pumps specified in the submittal.
 - Pumps shall connect to a discharge elbow using two guide rails extending from top of the station to the discharge elbow forming a watertight connection with the weight of the pump. No portion of the pump shall bear directly on the sump floor. Each pump shall be fitted with stainless steel chain with a rated lifting capacity of 50% greater than the pump unit weight.
- 38.4 PUMP STARTUP AND WARRANTY
- The pump manufacturer shall provide the services of a factory trained technician to provide installation, start-up, and operations assistance. The services shall be provided on a minimum of two job site trips. One trip will be during start up and installation and one trip will be after substantial completion at a time specified by the Owner.
 - All pump equipment shall be guaranteed for a period of three (3) years from the date of equipment start-up.. **Any defective portions of pump equipment and control panel, whether materials or workmanship, shall be replaced by pump equipment supplier at no cost to CWW during the term of the warranty.**
- 38.5 Wastewater lift stations must accommodate redundant pumps and include two (2) pumps, stainless steel lifting chains, stainless steel guide rails and brackets, cast in place aluminum access hatch, recessed hoist socket, duplex control panel, stainless steel float switch bracket and mercury float switches and all other materials required for installation into a concrete wet well and valve vault. Lift stations shall be constructed in accordance with the Typical Lift Station Detail below.
- Wet well ventilation shall be provided for 12 complete air changes per hour. Air shall be forced into the wet well by mechanical equipment.
 - In-lieu of ventilation requirements Explosion proof pumps and sulfate resistant concrete will be required.
- 38.6 Wet well and Valve Vault shall be constructed with pre-cast concrete sections conforming to ASTM C478. Pre-cast joints shall be sealed using a butyl mastic sealant conforming to ASTM C990 and shall be watertight.
- All pipe penetrations through wet-well shall conform to the requirements for pipe connections to manholes in these specifications.
 - A separate electrical conduit shall be installed through the wet-well wall for each pump power cord and large enough in diameter to easily remove and replace power supply cord from the top access hatch. Electrical conduits shall be sealed inside control panel to prevent corrosion caused by sewer gas, (No expanding foam may be used).
 - The concrete base shall have a minimum thickness of 12 inches and shall be poured on undisturbed earth. The base shall extend 1 foot outside of the finished manhole barrel. Prior to pouring the base, any water in the excavation shall be removed, and the base poured in the dry. Reinforcement steel consisting of #4 rebar (1/4 inch diameter) shall be placed at mid depth in the base at 12inch centers in two directions.
- 38.7 Wet well cover shall be constructed with an aluminum cast in place, automatic locking hatch covers of adequate size and positioned to permit pump removal without entering the wet-well as indicated on the Typical Lift Station Detail below. Access hatch shall have stainless steel safety chains or guard rails around openings

Cabot WaterWorks Standard Construction Specifications

conforming to OSHA – 29 Code of Federal Regulations, Subpart M, Fall Protection, 1926.502(k). The top edge height of top rails must be 42 inches plus or minus 3 inches. Mid-rails must be installed at a height midway between the top edge of the guardrail system. The guardrail system must be capable of withstanding a force of at least 200 pounds applied within 2 inches of the top edge in any outward or downward direction. When the 200 pound test is applied in a downward direction, the top edge of the guardrail must not deflect to a height less than 39 inches

38.8 Pump Lifting Hoist & Socket – A stainless steel hoist and embedded hoist socket with a weight rating to lift proposed pumps shall be provided by contractor.

38.9 PUMP CONSTRUCTION

- a). The pump components shall be of grey cast iron, ASTM A-48, Class 35B, with smooth surfaces. The lifting handle shall be of stainless steel. All exposed nuts or bolts shall be AISI type 316 stainless steel construction. All metal surfaces coming into contact with wastewater, other than stainless steel or brass, shall be protected by a factory applied spray coating of acrylic dispersion zinc phosphate primer with a polyester resin paint finish on the exterior of the pump.
- b). Pumps shall be provided with an integral motor cooling system. A motor cooling jacket shall encircle the stator housing, providing for dissipation of motor heat regardless of the type of pump installation. An impeller, integral to the cooling system and driven by the pump shaft, shall provide the necessary circulation of the cooling liquid (glycol blend) through the jacket.
- c). The combined service factor (combined effect of voltage, frequency and specific gravity) shall be a minimum of 1.15. The motor shall have a voltage tolerance of plus or minus 10%.
- d). The power cable shall be sized according to the NEC and ICEA standards and shall be of sufficient length to reach the junction box without the need of any splices. The outer jacket of the cable shall be oil resistant chlorinated polyethylene rubber.
- e). The motor horsepower shall be adequate so that the pump is non-overloading throughout the entire pump performance curve from shut-off through run-out.
- f). The pump shaft shall rotate on two bearings. Motor bearings shall be permanently grease lubricated with high temperature grease
- g). Each pump shall be provided with a tandem mechanical shaft seal system consisting of two totally independent seal assemblies. The seals shall operate in a lubricant reservoir that hydro-dynamically lubricates the lapped seal faces at a constant rate. The lower, primary seal unit, located between the pump and the lubricant chamber, shall contain one stationary and one positively driven rotating, corrosion resistant tungsten-carbide ring. The upper, secondary seal unit, located between the lubricant chamber and the motor housing, shall contain one stationary and one positively driven rotating, corrosion resistant tungsten-carbide seal ring. Each seal interface shall be held in contact by its own spring system. The seals shall require neither maintenance nor adjustment nor depend on direction of rotation for sealing. The position of both mechanical seals shall depend on the shaft.
- h). Each pump shall be provided with a lubricant chamber for the shaft sealing system. The lubricant chamber shall be designed to prevent overfilling and to provide lubricant expansion capacity. The drain and inspection plug, with positive anti-leak seal shall be easily accessible from the outside. The seal system shall not rely upon the pumped media for lubrication. The motor shall be able to operate dry without damage while pumping under-load. Seal lubricant shall be FDA Approved, nontoxic.
- i). Pump and motor shaft shall be the same unit. The pump shaft is an extension of the motor shaft. Couplings shall not be acceptable. The shaft shall be stainless steel ASTM/A151 431.
- j). The impeller shall be of ASTM A-532 (Alloy III A) 25% chrome cast iron dynamically balanced, semi-open, multi-vane, back swept, screw-shaped, non-clog design. The impeller leading edges shall be mechanically self-cleaned automatically upon each rotation as they pass across a spiral groove located on the volute suction. The screw-shaped leading edges of the gray iron impeller shall be hardened to Rc 45 and shall be capable of handling solids, fibrous materials, heavy sludge and other matter normally found in wastewater. The screw shape of the impeller inlet shall provide an inducing effect for the handling of up to 5% sludge and rag-laden wastewater. The impeller to volute clearance shall be readily adjustable by the means of a single trim screw. The impellers shall be locked to the shaft, held by an impeller bolt and shall be coated with alkyd resin primer.
- k). The pump volute shall be a single piece gray cast iron, ASTM A-48, Class 35B, non-concentric design with smooth passages of sufficient size to pass any solids that may enter the impeller. Minimum inlet and discharge size shall be as specified. The volute shall have a replaceable suction cover insert ring in which are cast spiral-shaped, sharp-edged grooves. The spiral grooves shall provide trash release pathways and sharp

Cabot WaterWorks Standard Construction Specifications

edges across which each impeller vane leading edge shall cross during rotation so to remain unobstructed. The insert ring shall be cast of ASTM A-532 (Alloy III A) 25% chrome cast iron and provide effective sealing between the multi-vane semi-open impeller and the volute housing.

- l). All stators shall incorporate thermal switches in series to monitor the temperature of each phase winding. The thermal switches shall open at 125°C (260°F), stop the motor and activate an alarm.
- m). A leakage sensor shall be available as an option to detect water in the stator chamber. The Float Leakage Sensor (FLS) is a small float switch used to detect the presence of water in the stator chamber. When activated, the FLS will stop the motor and send an alarm both local and/or remote.
- n). The thermal switches and FLS shall be connected to a Mini CAS (Control and Status) monitoring unit. The Mini CAS shall be designed to be mounted in any control panel.

38.10 CONTROL PANEL ENCLOSURE

- a). The control panel enclosure shall be rated Nema 4X Stainless Steel.
- b). The enclosure door shall be gasketed with a rubber composition material around the perimeter and shall be installed with a retainer to assure a positive weatherproof seal. The door shall open a minimum of 180 degrees. A padlock hasp shall be provided.
- c). A polished inner door shall be mounted on a continuous aluminum aircraft type hinge and shall contain cutouts for the protrusion of the circuit breakers and provide protection of the personnel from internal live voltages. All control switches, pilot indicators, elapsed time meters and other operational devices shall be mounted on the external surface of the dead front. The dead front door shall open a minimum of 150 degrees to allow for access to the equipment for maintenance. A %" break shall be formed around the perimeter of the dead front to provide rigidity.
- d). A back plate shall be manufactured from 12 gauge sheet steel and be finished with a primer coat and two coats of baked-on white enamel. All hardware shall be mounted using stainless steel thread screws. All installed devices will be permanently identified with engraved legends.
- e). A termination box, SS, shall be provided and sealed off from the panel to prevent the passage of sewer gas to the panel.

38.11 CONTROL PANEL REQUIREMENTS

- a). The panel power distribution shall include all necessary components and be wired with stranded copper conductors rated at 90 degrees "C". Conductor terminations shall be as recommended by the device manufacturer.
- b). The power system shall contain incoming power terminals, motor circuit breakers and control circuit breaker. All circuit breakers shall be heavy duty thermal magnetic or motor circuit protector similar and equal to Square "D" type "FAL". Each breaker shall be sized to adequately meet the operating conditions of the load. Breakers shall be indicating type, providing "on-off-tripped" positions of the handle. They shall be quick make-quick break on manual and automatic operation and have inverse time characteristics. Breakers shall be designed so that tripping of one pole automatically trips all poles.
- c). Motor starters shall be full voltage, NEMA rated with individual overload protection in each phase. Motor starter contacts and coil shall be replaceable from the front of the starter without removal of the starter from its mounted position. Overload heaters shall be block type, utilizing melting alloy spindles, sized for the full load amperage of the load.
- d). The following components will be required.
 - Plug-in phase/voltage monitor for each pump and supplied with two double pole double throw contacts NEMA 4 rated Hand-Off-Auto or spring-loaded Hand Auto switches for bypass control depending on the control selections
 - Run/failure lights as required.
 - Elapse run time meters.
 - Each pump shall be controlled by two (2)-120 volt ac, normally open, mercury float switches. The "Pump start" float shall activate a latching relay to start the pump. The "Pump off" float shall hold the relay closed until the water level drops below the pump off float.
 - A mechanical switch connected to both sets of floats shall be used to manually alternate lead and lag pumps.
 - 50-watt condensation heater and thermostat.
 - Control wiring to be 18 AWG copper-tinned rated at 105 degrees C.
 - Each wire shall be numbered corresponding to the wiring diagram.
 - Outside lighting with photo cell control.

Cabot WaterWorks Standard Construction Specifications

High Level Alarm with flashing alarm light and horn w/silence Button Alarm light to be visible above security fencing.

110 V outlets on side of control panel.

A final as built drawings with legends encapsulated in Mylar shall be attached inside of the front door.

- e). All control panels shall be listed by a nationally recognized testing laboratory (NRTL) and apply the certification necessary to indicate the NRTL approval.

38.12 ELECTRICAL SURGE PROTECTIVE DEVICE (SPD)

Provide and install at the Pump Station Electrical Service Entrance, a Surge Protective Device (SPD) of the parallel type, for each electrical phase of connection, with integral non-fused, non-circuit breaker disconnect and Diagnostic Test Set connection. Each semiconductor device (MOVs) shall be individually fused.

- a). Enclosure shall be NEMA 4/12 for indoor or outdoor wall mounted installation.
- b). Surge protection devices (SPD) shall protect all AC electrical circuits and electronic equipment from the effects of lightning induced voltages, external switching transients and internally generated switching transients.
- c). The SPD Manufacturer must be regularly engaged in the manufacture of surge suppression products for the specified categories for no less than ten (10) years and shall be ISO 9001 certified.
- d). The SPD and supporting components shall be guaranteed by the manufacturer to be free of defects in material and workmanship for a period of ten (10) years from the date of acceptance by Cabot Waterworks.
- e). Any SPD that shows evidence of failure or incorrect operation during the warranty period shall be replaced free of charge. Since "Acts of Nature" or similar statements typically include the threat of lightning to which the SPDs shall be exposed, any such clause limiting warranty responsibility in the general conditions of this specification shall not apply to this section.
- f). The SPD shall conform with current editions of UL 1449, and UL 1283, ANSI/IEEE C62.41 & 62.45 and NEMA LS-1.
- g). SPD's listed for 120/208V or 120/240V sub panels shall be UL 1283 listed, and must be a true sine wave tracking unit with EMI/RFI filtering. ANSI/IEEE C62.41-1991 Measured Limiting Voltage for sine wave tracking shall not exceed for A1 Ring Wave: L-N 60V; L-G 100V; L-L 70V & N-G 70V (Measurements taken from zero reference per NEMA LS-1; 180 degree phase Angle).
- h). The SPD shall protect all modes and there shall be seven discrete suppression circuits; 3 modes connected Line to Ground, 3 modes connected Line to Neutral, and 1 mode connected Neutral to Ground for 3-phase, 4-wire, plus ground voltage system. Line to Neutral ground is not an acceptable substitute for Line to Ground. Line to Neutral to Line and Line to Ground to Line (in combination) will be acceptable for Line to Line protection.
- i). SPD shall have a short circuit current rating greater than or equal to the AIC rating of the switchboard and be labeled accordingly. The unit shall be rated for service-entrance equipment.
- j). Maximum Continuous Operating Voltage (MCOV): The MCOV shall be greater than 115% of the nominal system operating voltage.
- k). The maximum clamping voltage of the Unit shall not exceed the current edition UL 1449.
- l). SPD must be of a no-power consuming design, except for indicator lights.
- m). SPD shall be suitable for application in Category C3 environments as described in ANSI/IEEE C62.41. SPD shall protect in all modes for a delta configuration (L-N, L-G, all phases & N-G). Tested surge current capacity of 150,000 amps per protection mode, minimum. SPD unit shall be capable of surviving at least 5,500 Category C3 (20KV, 10KA) impulses without failing or degrading the UL 1449 surge suppression rating more than 10%. Maximum Continuous Operating Voltage (MCOV) shall be not less than 115% of the facility's nominal operating voltage for 480 volt nominal systems. Single Impulse Surge current capacity of at least 100 KA in ALL modes, tested and verified with disconnect device in circuit. Surge Suppression Voltage for an IEEE Category B3/CI combination waveform per NEMA LS-I shall not exceed 925 volts L-N, 1725 volts L-L. SPD unit must not be affected by humidity, altitude, external EMI or RFI and must not generate EMI or RFI.
- n). SPD shall be equipped with transient counter plus an audible alarm actuated upon detection of fault condition.
- o). Submit product data and shop drawings with complete description of material components.
- p). Submit shop drawings of catalog data with complete description of materials and performance data.
- q). Submit a single impulse surge current test report issued by a nationally recognized testing facility and an ANSI/IEEE Category C3 (20KV, 10KA) life cycle test report. The test reports must demonstrate that the

Cabot WaterWorks Standard Construction Specifications

SPD unit can withstand, in each mode of its installed configuration, the specified values without failure of any internal component (MOVs, wiring, printed circuit board, fusing and disconnect).

- r). Drawings, with dimensions, indicating SPD mounting arrangement and lead length configuration, and mounting arrangement of any optional remote diagnostic equipment and assemblies.
- s). All submittals shall be approved by Cabot Waterworks prior to installation.
- t). The installing contractor shall install the SPD with short and straight conductors as practically possible.
- u). Contractor shall follow the SPD manufacturer's recommended installation practice as found in the equipment installation instructions (to be included in package with each unit).
- v). The installation shall comply with all applicable codes.
- w). All conductors associated with SPD devices shall be installed in conduit. Minimum conductor size shall be #8 AWG copper.

38.13 VALVE VAULT PIPING shall conform to the Lift Station Detail below.

- a). Discharge valves are to be located in a covered valve vault constructed with an aluminum cast in place, automatic locking hatch cover of adequate size and positioned to permit valve removal and equipped with a drain.
- b). Liquid Filled Discharge pressure gauges on each discharge line (of proper range) complete with isolation valves for ease of cleaning/repair.
- c). Emergency pump connection shall be provided for bypass of pump station and fitted with male Camlock adapter with cap. Bypass shall be located in valve vault downstream of pump isolation valves and extend 2 feet above valve vault.
- d). Flanged Ductile Iron pipe, cement lined or epoxy coated conforming to AWWA C115, pressure rating 250psi.
- e). Ductile Iron Pipe Fittings in valve vault shall conform to AWWA C110/ ANSI A21.10, pressure rating 250psi. Fittings shall have an epoxy coating conforming to AWWA C116/ANSI A21.16.
- f). Gate Valves - Isolation gate valves shall be provided conforming to AWWA standard C-509.
- g). Check Valves – Shall be AWWA C508 certified, Val-Matic Swing-Flex® Check Valve or equal.

38.14 STAND-BY GENERATOR AND SCADA

- a). Onsite Automatic auxiliary generator with automatic transfer switch will be required on lift stations. Auxiliary generators shall be sized to operate all pumps and equipment installed at the station. Fuel tanks for generators shall be sized for 24hour continuous operation of the lift station.
- b). Provide a Badger M2000 Electromagnetic Flow Meter or equal with polyurethane coating installed that provides total and instantaneous flow-rates with a 4-20mA output for communication with SCADA.
- c). Supervisory Control and Data Acquisition (SCADA) equipment shall be installed that monitors and alarms the following:
 - Pump 1 & 2 – Run/Stop
 - Pump 1 & 2 – Run Fail, (starter does not pull in)
 - Power Failure at lift station.
 - Communication Failure at lift station.
 - High Water level alarm at station.
 - Phase Failure at station.
 - Generator Run, Generator Fault
 - Flow Meter rate (gpm)
- d). SCADA equipment shall consist of the following components:
 - 24" X 24" X 8" NEMA 4 Enclosure (Hoffman or equivalent).
 - Allen Bradley Micrologix 1100 PLC.
 - Microwave Data Systems (MDS) SD4 Radio Modem.
 - 12VDC 5 Amp min Power supply.
 - Maxrad MYA-4505 antenna.

Cabot WaterWorks Standard Construction Specifications

- Coaxial Lightning arrester Polyphaser or equivalent.
 - UPS APC-350watt or equivalent.
 - 15-20' 1 ¼ antenna mast.
 - LMR400 transmission line.
 - The SCADA RTU shall be wired and programmed monitor and alarm the following:
 - SCADA computer programming at the Wastewater Treatment Facility for the new lift station.
 - Micrologix PLC programming at the Wastewater Treatment Facility for the new lift station.
 - Master Polling PLC programming at the 1 Million Gallon Tank on Panther Trail for the new lift station.
- 38.15 Lift Station shall have asphalt or concrete paved access roads to the wet well that will allow maintenance of pumps. Access roads shall conform to City of Cabot Street standards.
- 38.16 Security fencing shall be provided by chain link fence or a UV and mildew resistant vinyl fence tan. color (no white). Cabot WaterWorks shall approve fencing material prior to construction. Wood fences will not be acceptable due to long term maintenance requirements.
- a). **Fabric:** 6' high, 9-gauge, Class 2 galvanized coating (2.0 oz. /ft²), (2" mesh) chain link. Install by securing one end and applying sufficient tension to provide a smooth uniform appearance free from sag. The fabric can be cut by untwisting a picket and attaching each span independently at all terminal posts. Use stretcher bars with tension bands or other suitable devices at 15 in. maximum intervals. The fence fabric should be installed 2" above ground level.
- b). **Posts and Rail Materials:** Schedule 40 Galvanized Tubing or conforming to ASTM F 1043, Group IV. High-strength steel pipe triple coated per ASTM F 1043: external coating, Type B; internal coating, Type D.
- c). **Top Rail:** 1 5/8" OD, 2.27 lbs. per foot. Top rail 21' length, joined with 6" long couplings with .07" minimum wall thickness.
- d). **Line Post:** 2 3/8" OD, 3.65 lbs. per foot. Line posts set 10' on center maximum spacing. Concrete footing: 8" diameter, 36" depth
- e). **Terminal Post:** 2 7/8" OD, 5.79 lbs. per foot. Concrete footing: 10" diameter, 36" depth.
- f). **Double swing gate Post:** 4" OD, 9.10 lbs. per foot. Concrete footing: 12" diameter, 36" depth
- g). **Post Braces** shall be provided for each gate, comer, pull, and end post for use when top rail is omitted or with fabric 6 feet or more in height, and shall consist of a round tubular brace extending to each adjacent line post at approximately mid-height of the fabric, and a truss consisting of a rod not less than 5/16 inch nominal diameter from the line post back to the gate, comer, pull, or end post, with a turn buckle or other equivalent provision for adjustment. Truss rods may be eliminated in any line of fence where there is a continuous center rail.
- h). **Swing Gates: Provide a 4' wide and a 12' wide swing gate,** Gates shall be welded steel frame of 1.9" OD, 2.27 lbs. per foot, braced and trussed a minimum of every 8 feet. Fabric: 9-gauge, Class 2 galvanized coating (2.0 oz./ft²), (2" mesh) chain link attached with 9 gauge steel, 1.8 oz. galvanized coated tie wire spaced 15" on center.
- Gate Frames shall conform to ASTM Specifications F1043 or F1083, or a combination thereof, and shall match that selected for any adjoining fence framework. Welded joints shall be coated in accordance with Practice A780
- Gate Hinges—Hinges shall be structurally capable of supporting the gate leaf and allow the gate to open and close without binding. The hinges shall be so designed to permit the gate to swing a full 180°.
- Single Gate Latch —Gate latch shall be capable of retaining the gate in a closed position and shall have provision for a padlock.
- Double Gate Latch —Gate latch shall be a drop rod or plunger bar arranged to engage the gate stop. Locking devices shall be constructed so that the center drop rod or plunger bar cannot be raised when the gate is locked. The latching devices shall have provision for a padlock.
- Gate Stops—Gate stops shall be provided for all double gates.

Cabot WaterWorks Standard Construction Specifications

Keepers shall be provided for each gate leaf over 5 ft.

- i). **Tension or Stretcher Bars:** Hot-dip galvanized steel with a minimum length 2 inches less than the full height of fabric, a minimum cross section of ¼ inch x ¾ inch, and Class 2 galvanized coating (2.0 oz. /ft²) in accordance with ASTM F-626. Provide bars for each gate and end post, and two bars for each corner and pull post.
- j). **Tension Wire:** 7 Gauge coil spring galvanized tension wire attached to the bottom of fence fabric with 9-gauge steel hog ring spaced 24” on center.
- k). **Barbed Wire:** 3 strands of 12½ gauge 4 point barbs at 5” centers on a 45 degree pressed steel barb wire arm the top wire shall be approximately 12” horizontally from the fence line with the other wires spaced uniformly. The barbed wire arm shall be of sufficient strength to withstand a weight of 250 pounds applied at the outer strand of barbed wire. Barbed Wire shall be pulled tight to remove all sag. Firmly install in the slots of extension arms and secure it to a terminal post utilizing terminal post band arms or brace bands or other suitable devices.
- l). **Tension Bands:** fabricated of galvanized steel in accordance with ASTM F-626 and shall be installed attaching the fabric and stretcher bars to all terminal posts at intervals not exceeding 15”. Tension bands shall be formed from flat or beveled steel and shall have a minimum thickness after galvanizing of 0.078 inch and minimum width of 3/4 inch for posts up to 4” dia.
- m). **Tie wire:** 9 gauge steel with 1.8 oz. galvanized coating tie wire shall be spaced 15” on center for line posts and 24” on center for rails.
- n). **Post footing:** Posts shall be set in concrete with a 28-day compressive strength of at least 4,000 psi conforming to ASTM C94, “Standard Specification for Ready-Mixed Concrete” or ASTM C387, “Standard Specification for Packaged, Dry, Combined Materials for Mortar and Concrete”.

38.17 Public notice sign (12” X 18”) stating “If alarm sounds or light is flashing, please call 743-1428,” to be installed on outside of security fence for visibility of public.

38.18 Landscaping and finished grading shall be designed to prevent storm run-off from collecting at the lift station.

38.19 Lift Stations shall conform to the standard detail below.

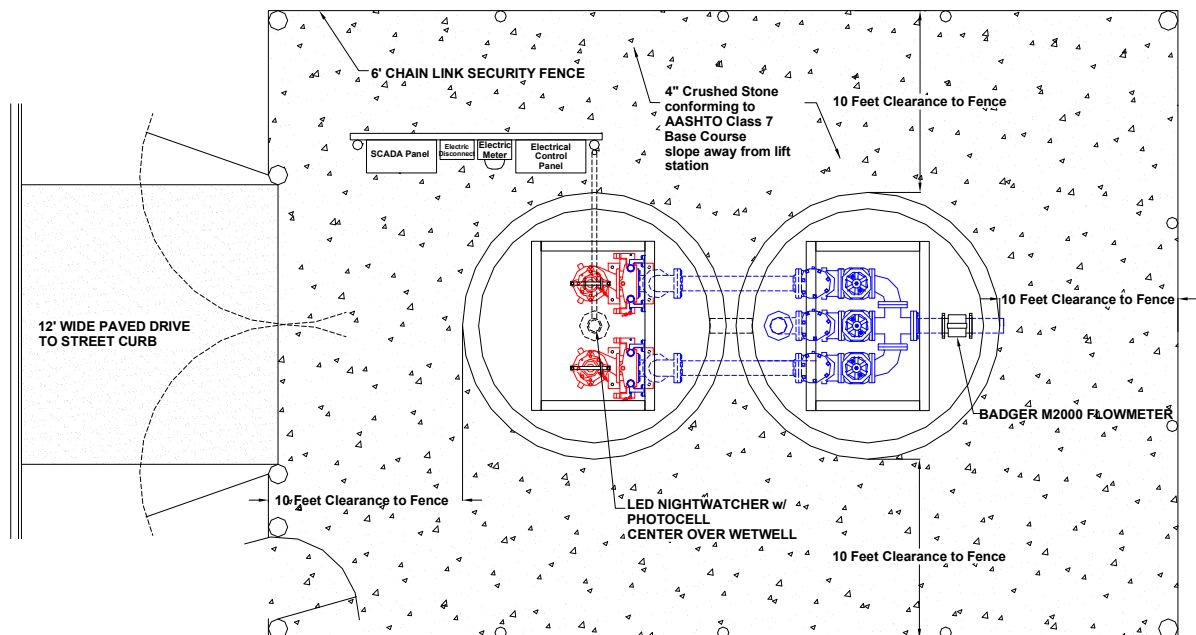

Typical Lift Station Plan View

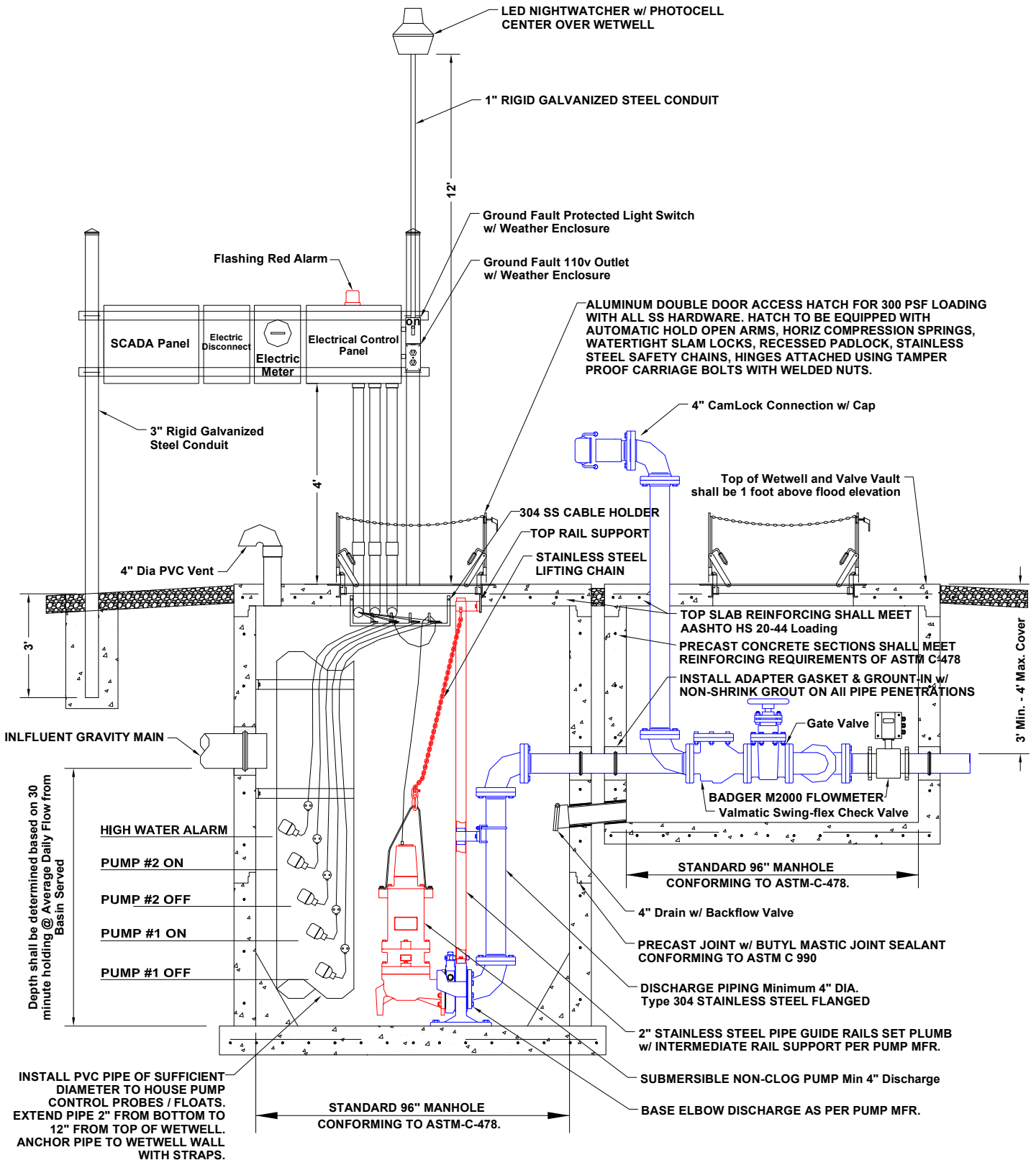

Typical Lift Station Detail

Cabot WaterWorks Standard Construction Specifications

39. WASTEWATER FORCE MAINS

- 39.1 All requirements of Sections 1.0 through 28.0 of these specifications shall apply to sewer force mains.
- 39.2 All requirements for Tracer Wire and Marking Tape shall apply to sewer force mains.
- 39.3 Force mains shall be sized at design pumping rates for a cleansing velocity of 2 feet per second. Minimum force main diameter shall be four inches.
- 39.4 Sewer line Sign Markers shall be installed every 1000 feet and at highway crossings, creek crossings, and changes in direction, railroad crossings or other areas of concern. Signs shall conform to detail in Section 7.10. Sign Markers shall not be disturbed during construction.
- 39.5 Automatic (ARI, D-025, or better) reinforced nylon, air/vacuum relief valves designed for use with sewage shall be installed at high points on the force main. Air/Vacuum Relief valve assemblies shall include carbon filters, inlet and outlet ports for back flushing, and stainless-steel ball valves to facilitate inspection and repair and be installed in a valve box of adequate size to accommodate maintenance and repair.

40. LOW PRESSURE GRINDER PUMP SYSTEMS

- 40.1 All requirements for WASTEWATER FORCE MAINS shall apply for Low pressure Grinder Pumps.
- 40.2 Service Laterals for Low Pressure Grinder Pump Systems shall be installed as follows:
 - a). The pump discharge pipe from the basin to the street service shall be a minimum 1¼" AWWA Cross-linked Polyethylene (PEX). Pipe connections shall be female threaded Brass pack joint couplings sized for the pipe OD. "Fernco" couplings are prohibited on the basin discharge piping.
 - b). All 4" DWV pipe and 1.5" PEX pipe shall be bedded with Select Granular Bedding. A Green 12-gauge tracer wire shall be installed in the trench with the 1.5" PEX pipe and extended into the valve box at the street and extended up above ground at the basin wrapped around a screw on the lid. Backfill around the basin shall be 5/8" gravel up to a level 6" above all piping. All backfill shall be compacted to provide the same bearing capacity as adjoining undisturbed native soil. The installer will be responsible for cost to repair damaged pipe and tank fittings caused by settlement.
 - c). If the 1.5" PEX crosses under a sidewalk or driveway, a 2" PVC sleeve (encasement) shall be installed under concrete surfaces.
 - d). Service line pipe shall be bedded in accordance with Section 6. of these specifications
 - e). Polypropylene or Schedule 80 curb stop valves shall be installed between 18" below final grade at the property line to each Building and shall be pressure-tight in both directions. The valve handle shall have shall include a ratcheting feature to prevent breaking from over-torquing. EPDM or Buna-N O-rings shall be used to provide a redundant, watertight seal on the stem. A spherical, PVC ball shall be supported in molded, polyethylene seats to provide watertight seals in either direction, as well as maximum flow capacity and ease of operation. Valves shall be designed to withstand a working pressure of 150 psi minimum.
 - f). Check Valves: Check valves shall be injection-molded from non-corroding, glass-fiber-reinforced PVC, Schedule 80 PVC, or brass for durability. The check valve flapper shall include a non-fouling, integral hinge. The check valve will provide a full-ported passageway and shall introduce a friction loss of less than 6 inches of water at maximum rated flow. The hinge shall be an integral part of the flapper assembly, providing a maximum degree of freedom to ensure seating at low back pressure. All internal metallic internal parts shall be stainless steel. No spring-loaded check valves will be permitted.
 - g). Ferrous Cast Iron Valve boxes shall with a cast iron lid. The Cast Iron lid shall have "Sewer" cast into the lid with raised letters. The Cast Iron lid shall seat flush with the top of the valve box. The valve box shall extend above grade at all times until completion of building construction and final grading on each lot.

Cabot WaterWorks Standard Construction Specifications

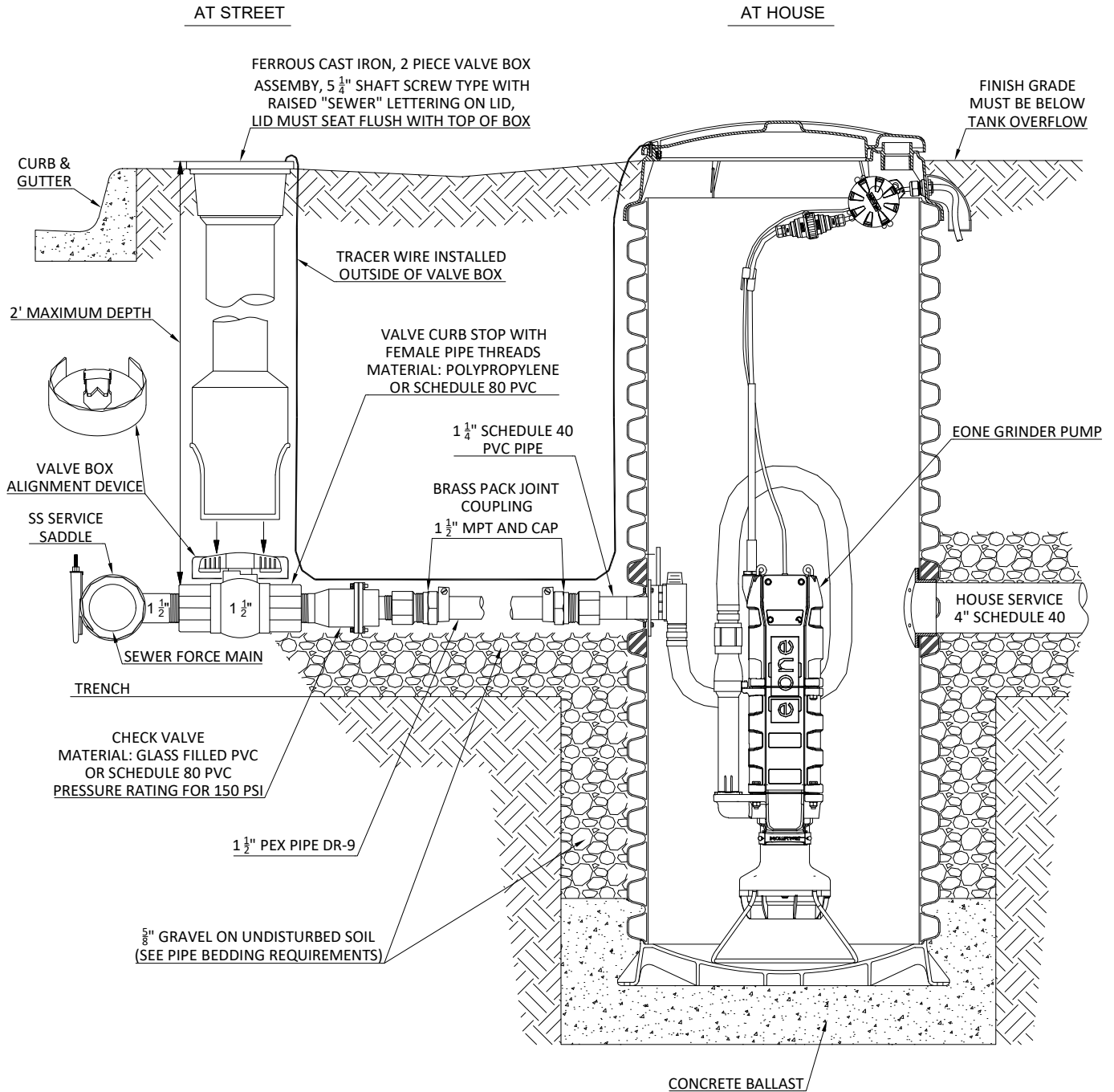

Low Pressure Grinder Pump Service Line Detail

- 40.3 Grinder pump piping systems shall be sized to maintain flow between 2 and 3 fps velocity based on the number of pumps operating simultaneously.
- 40.4 Grinder pumps shall be E/ONE Series 1010, positive displacement pumps rated for 14gpm @ 0' TDH and 9gpm @ 138' TDH and shall consist of:

- E/ONE Grinder Pump MODEL 1010
- 30 x 74" HDPE Basin with Stainless Steel Band Clamp
- Model SENTRY Simplex Alarm Panel
- 32' of Power Cable with EQD
- Redundant Check Valve

TYPICAL EONE DUPLEX STATION FOR COMMERCIAL APPLICATIONS

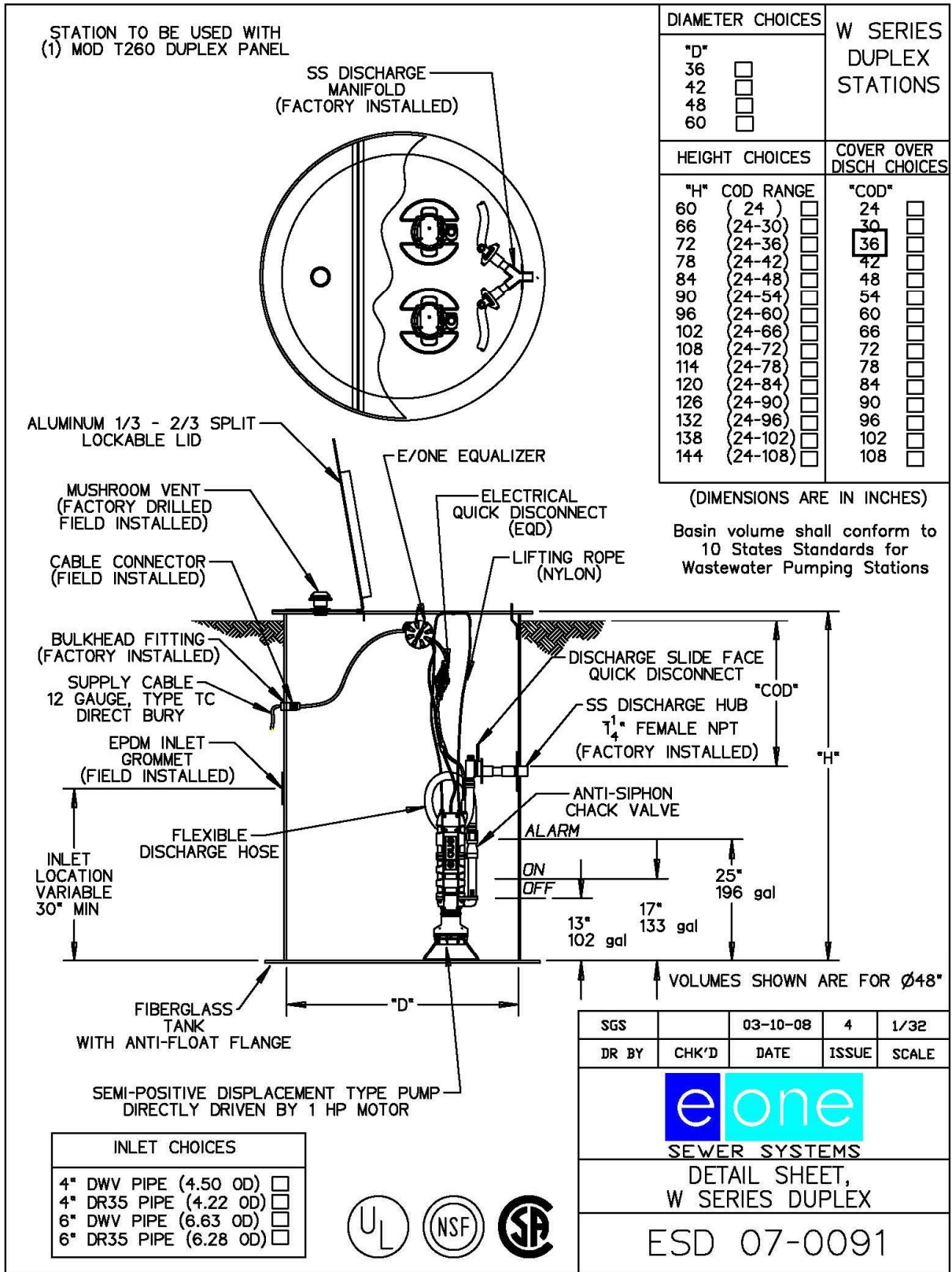

Note: Commercial Grinder Pump Stations shall be provided with a standby power generator or a basin sized to handle 24 hour wastewater retention capacity.

Cabot WaterWorks Standard Construction Specifications

41. RESTORATION AND CLEAN-UP OF JOB SITE

- 41.1 Restoration and clean-up of all work performed in roadways, either within or outside paved areas, shall be performed in strict accordance with specifications of the regulating local authorities and governmental agencies.
- 41.2 Contractor shall provide all equipment, materials and labor to restore areas disturbed by construction to their original condition or better, as nearby as is possible in accordance with good engineering and construction practices.
- 41.3 Promptly upon completion of work and at his expense, Contractor shall remove from the site, tools, equipment, temporary structures, barricades and surplus materials. All waste and debris shall be disposed in accordance with Federal, State and local regulatory agencies having jurisdiction of same.
- 41.4 The CONTRACTOR shall remove all vegetation that has been cut or has died as a result of the work. There shall be no burning on the job site unless approved, in advance, by the ENGINEER and other agencies involved.
- 41.5 The CONTRACTOR shall restore the topography of the work site to facilitate proper drainage of all adjacent lands.
- 41.6 No work will be accepted as complete until RESTORATION AND CLEAN-UP are completed as required.
- 41.7 Guarantee as set forth in these specifications shall apply hereunder also.

42. GUARANTEE

- 42.1 Contractor shall guarantee all work performed under this contract for a period of one year from the date of completion and acceptance by CWW.
- 42.2 Any defective portions of such work which is under the Contractor's jurisdiction, whether materials or workmanship, shall be replaced by Contractor at no cost to CWW during the term of the guarantee.

43. RECORD DRAWINGS & FINAL CONSTRUCTION COSTS

- 43.1 During the course of work, the contractor or his engineer shall continually maintain a set of legibly marked up prints, drawings and sketches, shop drawings, and Product Submittals to be utilized for record documents showing any changes made during the construction process.,.
- 43.2 Record actual revisions to the Work concurrent with construction progress.
- 43.3 Specifications, Record documents, and Shop Drawings: Legibly mark each item to record actual construction or product installed.
- 43.4 Submit documents to Engineer prior to final Application for Payment.
- 43.5 Upon completion of the Facilities, Engineering Firms responsible for the project shall deliver to Cabot WaterWorks "as-built drawings" and AUTOCAD electronic files of the Facilities referenced to Arkansas State Plane South coordinates. All elevations and contours are to be referenced to the North American Vertical Datum of 1988 (NAVD88). The drawings shall include the actual in-place alignment and grade of the water and wastewater lines, manholes, valves, service lines, meter boxes and lift stations with tie down measurements, not to exceed a distance of 100 feet, as necessary to assure easy location of all critical elements of the Facilities. Each change in direction of pipe with bends shall be reflected on record drawings with a minimum of two tie-down measurements, from street curb line and a second tie-down (property pins) acceptable to Cabot WaterWorks. As-Built drawings shall include road and street right-of-ways with storm water drainage facilities and utility easements. Developer shall provide a copy of court recorded final plats and easements.